

DEPARTMENT OF THE ARMY TECHNICAL MANUAL

TM 55-4018-1

DEPARTMENT OF THE AIR FORCE TECHNICAL ORDER

TO 38G1-6-21

CUMMINS
PT FUEL SYSTEM

DEPARTMENTS OF THE ARMY AND THE AIR FORCE
SEPTEMBER 1956

This technical manual contains copyrighted material

DEPARTMENTS OF THE ARMY AND
THE AIR FORCE
WASHINGTON 26, DC., 5 September 1966

TM 55-4018-1/TO 88G1-6-21 is published for the use of all concerned.

[AG 406 (27Jul 56)]

BY ORDER OF THE SECRETARICE OF THE ARMY AND THE AIR FORCE:

MAXWELL D. TAYLOR,
General, United States Army,
Chief of Staff

OFFICIAL:

JOHN A. KLEIN,
Major General, United States Army,
The Adjutant General.

N. F. TWINING,
Chief of Staff, United States Air Force.

OFFICIAL:

E. E. TORO,
Colonel, United States Air Force,
Air Adjutant General.

DISTRIBUTION:

Active Army:

Tec Svc, DA (2)
Army Maint Bd (2)
Trans Bd (1)
Mq CONARC (2)
Army AA Comd (2)
OS Maj Comd (2)

OS Base Comd (1)
Log Comd (2)
MDW (1)
Armies (2)
Trans Sup & Maint Comd (15)
Trans Sch (

Trans Sec, Gen Depots (5)
Trans Depots (5)
POE (OS) (1)
Trans Terminal Comd (1)
Army Terminal (1)
OS Sup Agencies (1)

NG: None.

USAR: None.

For explanation of abbreviations used, see

☆U.S. GOVERNMENT PRINTING OFFICE:

TABLE OF CONTENTS

SECTION I	Operating Principles	1-1 to 1-6
	Fuel Pump	1-2
	Gear Pump	1-2
	Pressure Regulator	1-3
	Throttle,	1-3
	Governors	1-3
	Injectors	1-5
	Supply Lines	1-6
	Shut-down Valve	1-6
	Inlet Connections	1-6
	Drain Lines	1-6
SECTION II	Fuel System Installation	2-1 to 2-8
	Changing Systems	2-1
	Fuel Pump	2-1
	Injectors	2-1
	Fuel Manifolds	2-2
	Drive Coupling	2-2
	Fuel Supply Tank	2-3
	Fuel Lines	2-3
	Installation Diagrams	2-4
	Shut-down Valve	2-4
	Tachometer Cable	2-4
	Saddle Tanks	2-4
SECTION III	Service and Adjustments	3-1 to 3-5
	Fuel Pump Screen	3-1
	Fuel Filter Element Changes	3-1
	Injector Adjustment	3-2
	Governor Adjustments	3-2
	Checking a PT Pump on the Engine	3-4
	Cleaning Injectors on the Engine	3-4
SECTION IV	Fuel Pump Assembly and Disassembly	4-1 to 4-26
	Disassembly	4-1
	Unit Rebuilding	4-5
	Assembly	4-15
	Testing	4-20
SECTION V	Maintenance and Testing of Injectors	5-1 to 5-2
SECTION VI	Trouble-Shooting the Fuel System	6-1 to 6-24

INDEX

Adjusting engine idle speed.....	3-2	Governor spring pack assembly.....	4-4, 4-16
Adjusting fuel pump on engine	3-4	Governor, torque converter.....	1-4, 3-3
Adjusting injectors.....	3-2	Governor, variable-speed	1-4, 3-3, 4-17
Adjusting standard governor.....	3-2	Governed speed	4-20, 4-22, 4-23, 4-24
Adjusting torque converter governor.....	3-3		
Adjusting variable-speed governor	3-3	Idle governor	1-3, 3-2, 4-16
Air leak check	4-23	Injectors	1-5, 2-1, 3-2, 5-1
Assembly of fuel pump.....	4-15	Injector adjustment	3-2
		Injector cleaning, bench.....	5-1
Calibration of fuel pump	4-20	Injector cleaning, on engine	3-4
Calibration of fuel pump on engine.....	3-4	Inlet manifold.....	2-2
Calibration pressures.....	4-20, 4-24		
Capscrews and washers.....	4-6	Main housing	4-6
Change fuel filter.....	3-1	Manifold orifice	4-20
Changing fuel systems.....	2-1	Manifold pressure	4-20, 4-22, 4-24
Clean fuel pump screen	3-1	Material for calibrating pumps	4-21
Clean injectors	5-1	Maximum speed governor	1-3, 3-2, 4-16
Clean injectors on engine	3-4		
		Needle bearings.....	4-6
Diagram, fuel piping.....	2-4	Operating principles.....	1-1
Disassembly, fuel pump	4-1	Orifice specifications	4-21
Disassembly, injector	5-1	Orifice, idle.....	4-21
Drain manifold.....	1-6, 2-2	Orifice, manifold	4-21
Drive coupling.....	2-2	Orifice, cleaning	5-1
Drive shaft bushing	4-6		
		Parts replacement	4-6
Front cover assembly.....	4-2, 4-9	Piping, fuel	2-4
Fuel filter.....	2-3, 3-1, 4-4, 4-15	Pressing lubricant	4-6
Fuel inlet connections	1-6, 2-1	Pressure regulator	1-3, 4-1, 4-19, 4-22
Fuel lines	1-2, 1-6, 2-2, 2-	Pressure regulator spring load	4-22
Fuel manifolds	1-6, 2-2	Pressure regulator setting	4-20, 4-22, 4-24
Fuel pressure adjustments	3-4, 4-21	Priming the pump	3-2
Fuel pump.....	1-2, 2-1, 4-1, 4-20	Pump, check on engine	3-4
Fuel pump assembly.....	4-15	Pump gear.....	1-2, 4-3, 4-7
Fuel pump disassembly	4-1	Pump testing	4-20
Fuel supply tank.....	2-3, 4-21		
Fuel system installation.....	2-1	Screen, fuel	3-1, 4-4, 4-15
		Section I Operation Principles	1-1
Gear pump.....	1-2, 4-2, 4-7	Section II Fuel System Installation	2-1
General instructions	4-5	Section III Fuel System Service and	
Governor barrel.....	4-7	Adjustments	3-1
Governor disassembly.....	4-10	Section IV Fuel Pump Assembly and	
Governor, idle and maximum speed.....	1-3, 3-2, 4-16	Disassembly.....	4-1
Governor plunger	4-2, 4-8, 4-18		
Governor spring guide	4-16		

INDEX

Section V Maintenance of Injectors	5-1	Test equipment	3-4, 4-21, 5-1
Section VI Trouble Shooting the		Throttle.....	1-3, 4-2, 4-18
Fuel System.....	6.1	Throttle sleeve.....	4-7
Service and adjustments.....	3-1	Throttle leakage.....	4-20, 4-23, 4-24
Shut-down valve	1-6, 2-3, 4-19	Tools	4-5
Spring pack housing	4-4, 4-16	Torque converter governor	1-4, 3-3
Supply lines	1-6, 2-3	Trouble shooting	6-1
		Trouble shooting charts	6-12
Table, injector adjustment	3-2	Unit rebuilding	4-5
Table, idle speed	4-20, 4-24	Variable-speed governor.....	1-4, 3-3
Table, manifold pressure.....	4-20, 4-24	Vise and holding fixture	4-1
Tachometer drive.....	4-5, 4-8, 4-15		

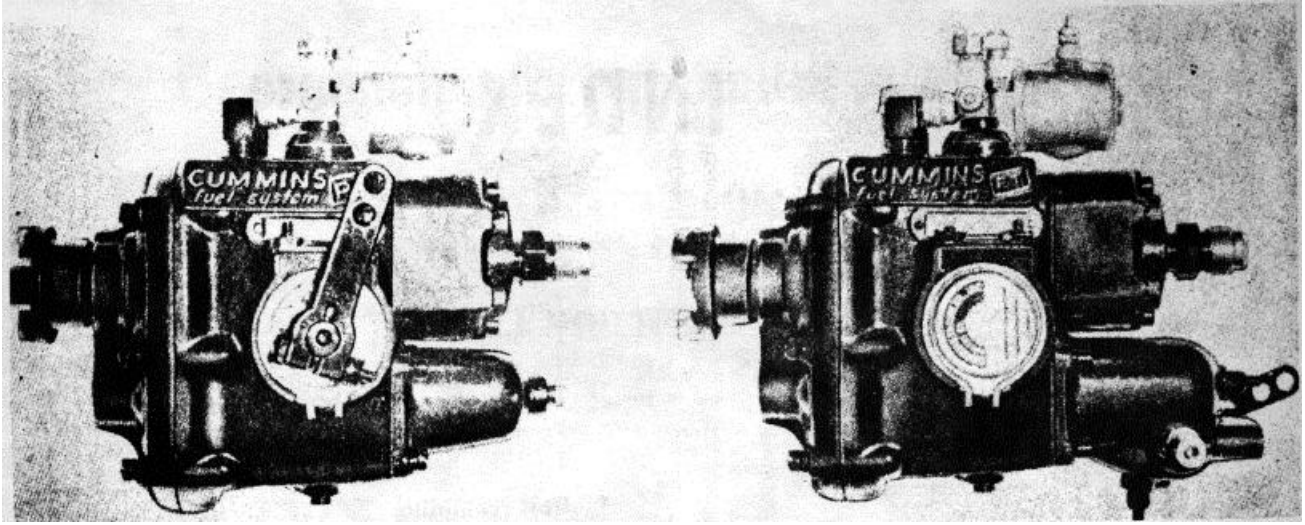

PT fuel pump with maximum speed governor

PT fuel pump with variable speed governor

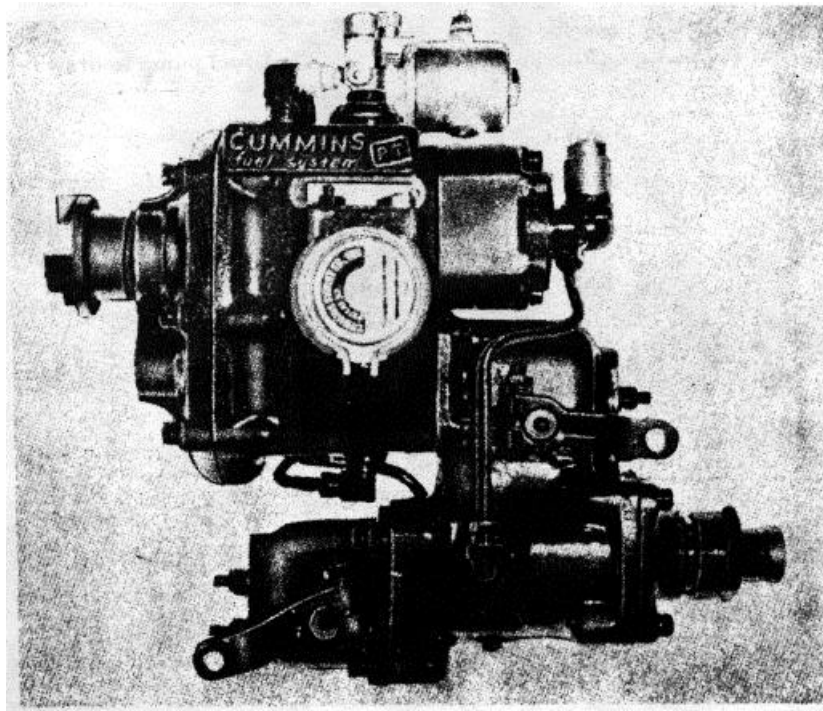

PT fuel pump with torque converter governor

Operation and Maintenance

CUMMINS PT FUEL SYSTEM

SECTION I

Operating Principles

Cummins PT Fuel System is a completely new application of basic hydraulic principles to the diesel engine fuel system. It is a Cummins design for Cummins Diesels. The identifying letters, "PT," are an abbreviation for "pressure-time."

The principle of the PT Fuel System is based on the fact that by changing the pressure of a liquid flowing

through a pipe you change the amount of liquid coming out of the open end: Increasing the pressure increases the flow or the amount of liquid delivered, and vice versa. In applying this simple principle to the diesel fuel system it was necessary to provide:

1. A fuel pump to draw fuel from the fuel tank

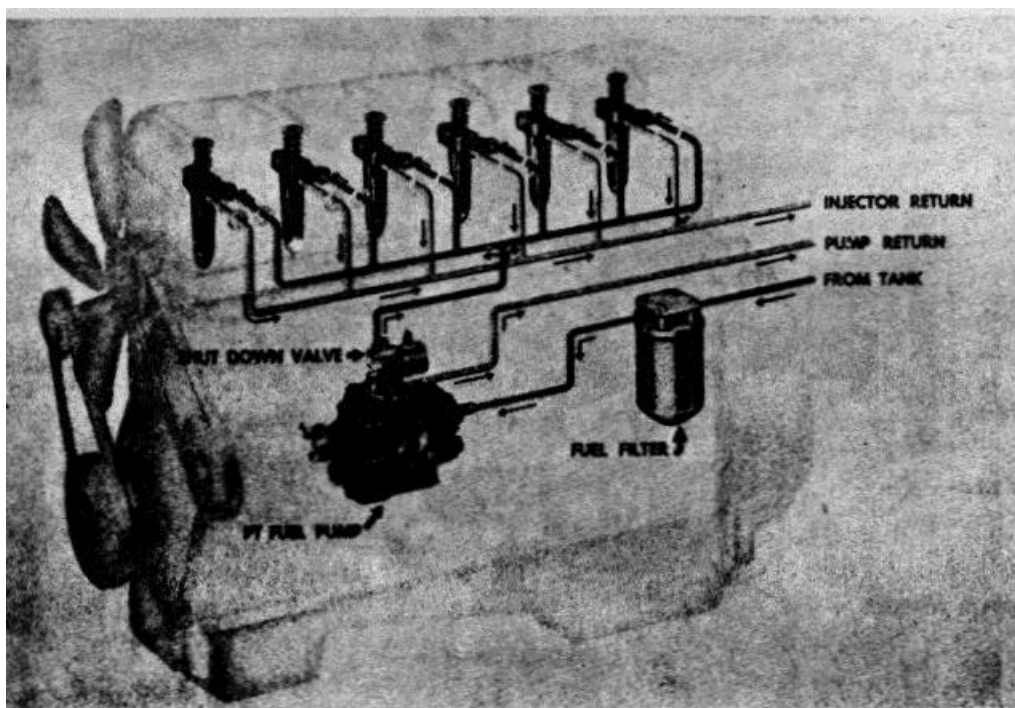

Figure 1-1. PT fuel system-Fuel flow diagram

and deliver it to individual injectors for each cylinder.

2. A means of controlling the pressure of the fuel being delivered by the fuel pump to the injectors so the individual cylinders would receive the right amount of fuel for the power required of the engine.
3. Fuel passages of the proper size and type so that the fuel will be distributed to all injectors and cylinders with equal pressure under all speed and load conditions.
4. Injectors to receive low-pressure fuel from the fuel pump and deliver it into the individual combustion chambers at the right time, in equal quantity and proper condition to burn.

The PT Fuel System consists of the fuel pump (with governor), the supply and drain lines, and the injectors. Each of these is described in detail in the paragraphs following.

Fuel Pump

The fuel timing is made up of three main units:

1. A gear pump which draws fuel from the supply tank and delivers it under pressure through the pump and supply lines to the individual injector.
2. The pressure regulator which limits the pressure of the fuel to the injectors.
3. The governor and throttle which act independently of the pressure regulator to control fuel pressure to the injectors.

The fuel pump is coupled to the compressor or fuel pump drive which is driven from the engine gear train. The fuel pump main shaft turns at engine crankshaft speed, and drives the gear pump, governor and tachometer shaft.

The location of these units in the fuel pump housing is indicated in Fig. 1-2.

GEAR PUMP: The gear pump is located at the rear of the fuel pump and it is driven by the

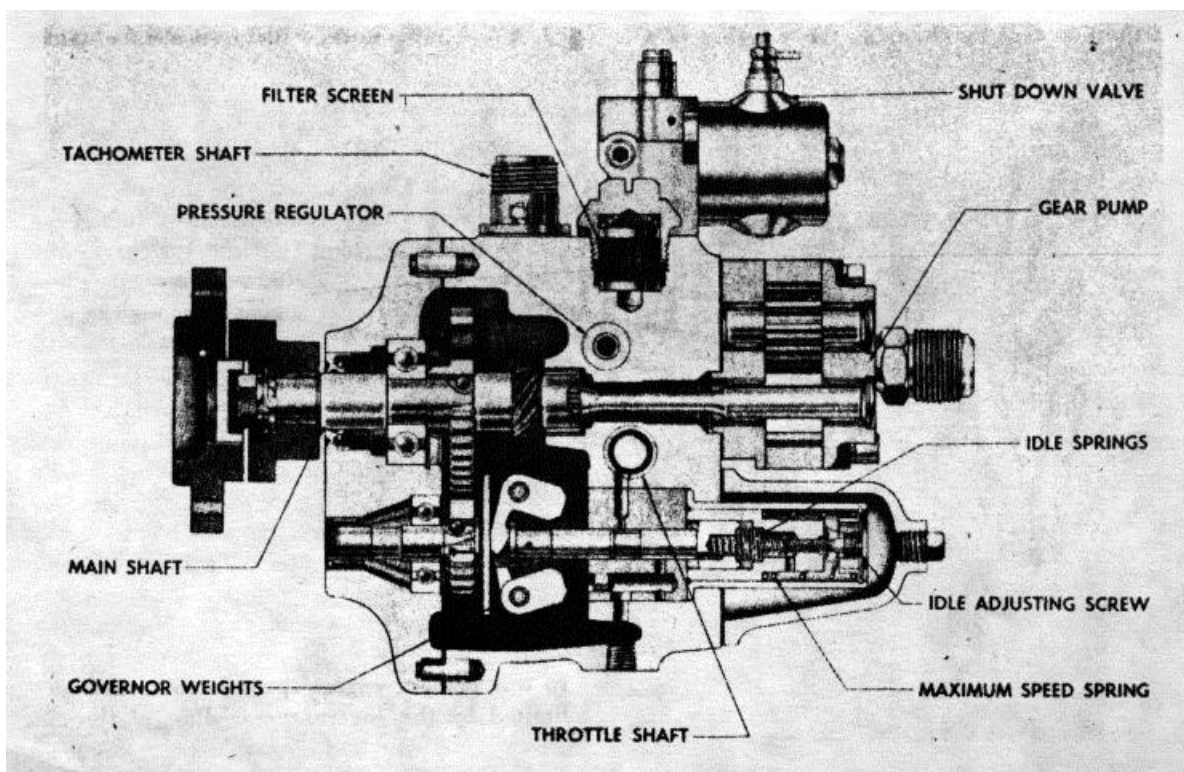

Figure 1-2. Cross section PT pump with idling and high speed mechanical governor

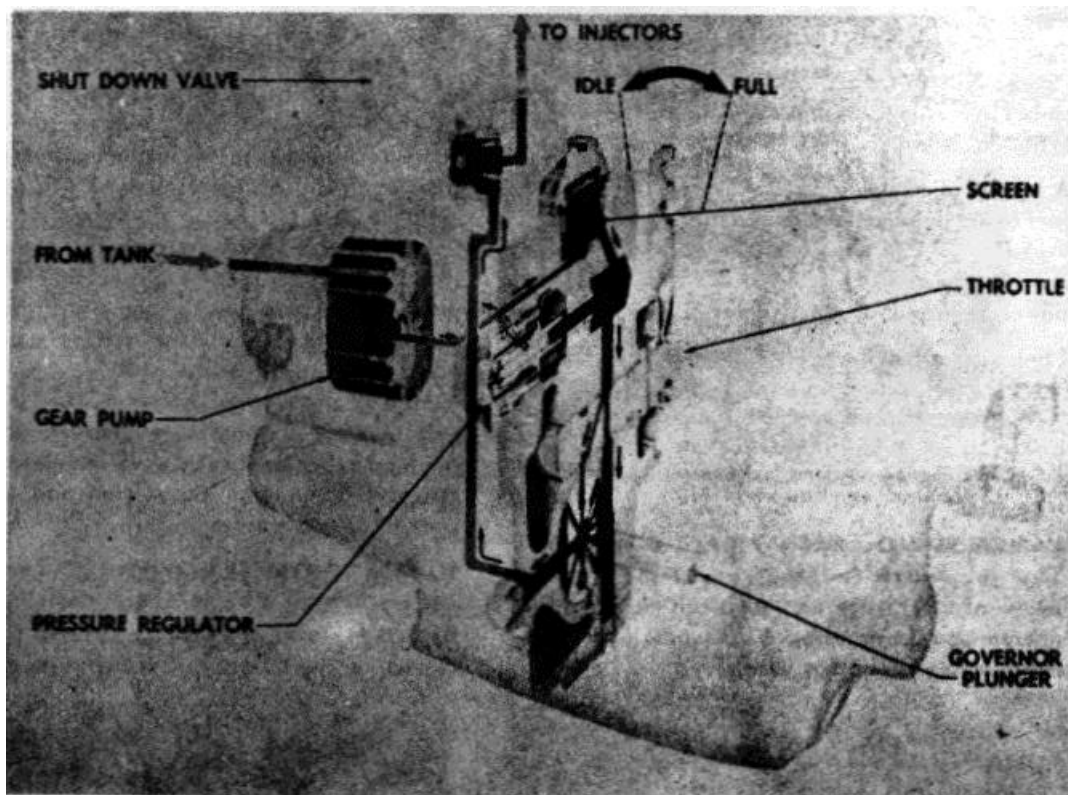

Figure 1-3. Fuel flow through the fuel pump

main shaft. This unit consists of a single set of gears to pick-up and deliver fuel throughout the fuel system. From the gear pump fuel flows through the filter screen and to the pressure regulator.

PRESSURE REGULATOR: The pressure regulator is a by-pass valve to regulate the fuel, under pressure, supplied to the injectors. By-passed fuel flows back to the suction side of the gear pump.

THROTTLE: Fuel for the engine flows past the pressure regulator to the throttle shaft. Idle fuel passes around the shaft to the idle jet in the governor. For operation above idle, fuel passes through the throttling hole in the shaft and enters the governor through the primary jets.

IDLING AND HIGH-SPEED MECHANICAL GOVERNOR: Mechanical governor action is provided by a system of springs and weights, and it has two functions. First; the governor maintains sufficient fuel for idling with the

throttle control in idle position and second; it cuts off fuel above maximum rated rpm. The idle springs in the governor spring pack position the governor plunger so the idle fuel jet is opened enough to permit passage of fuel to maintain engine idle speed.

During operation between idle and maximum speeds, fuel flows through the governor to the injectors in accord with the engine requirements as controlled by the throttle and limited by the pressure regulator. When the engine reaches governed speed, the governor weights move the governor plunger and fuel passages to the fuel supply manifold are shut off. At the same time another passage opens and dumps the fuel to the supply manifold back into the main pump body. In this manner engine speed is controlled and limited by the governor regardless of throttle position. Fuel leaving the governor travels through the shut-down valve, inlet supply lines and on into the injectors.

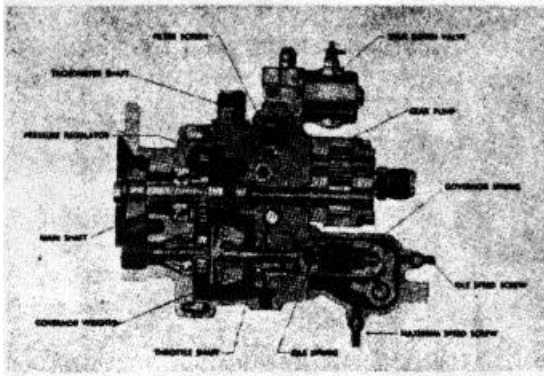

Figure 1-4. Flange mounted fuel pump with variable speed governor

constant speed but where extremely close regulation is not necessary.

Adjustment for different rpm can be made by means of a lever control or adjusting screw. At full-rated speed, this governor has a speed droop between full-load and no-load of approximately eight percent. A cross-section of this governor is shown in Fig. 1-4.

As a variable-speed governor, this unit is suited to the varying speed requirements of cranes, shovels, etc., in which the same engine is used for propelling the unit and driving a pump or other fixed-speed machine.

As a constant-speed governor, this unit provides control for pumps, nonparalleled generators and other applications where close regulation (variation between no-load and full-load speeds) is not required.

TORQUE CONVERTER GOVERNOR: When a torque converter is used to connect the engine with its driven unit, an auxiliary governor may be driven off the torque converter output shaft to

VARIABLE-SPEED MECHANICAL GOVERNOR: This governor is designed to meet the requirements of machinery on which the engine must operate at a

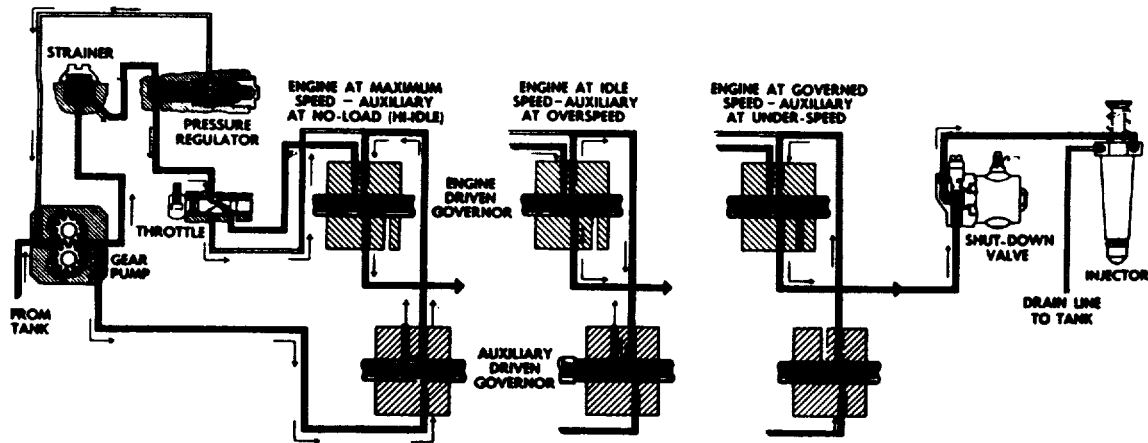
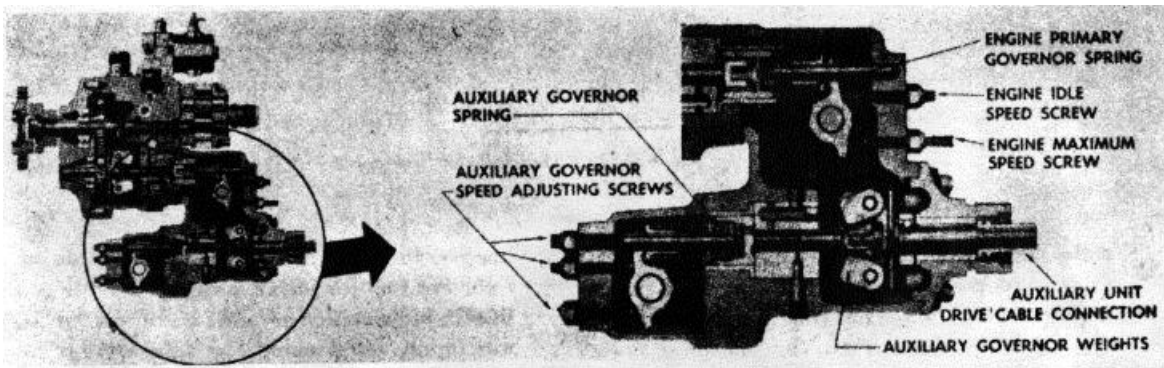

Figure 1-5. Cross Action and fuel flow through torque converter governor and fuel pump

exercise control over the engine governor and to limit converter output shaft speed. The engine governor and the converter governor must be adjusted to work together.

The PT torque converter governor is fundamentally two mechanical variable-speed governors in series - one driven by the engine and the other by the converter. See Figs. 1-4 & 1-5.

The engine governor, in addition to giving a variable engine speed acts as an overspeed and idle-speed governor while the converter-driven governor is controlling the engine. Each governor has its own control lever and speed adjusting screws.

The converter driven governor works on the same principles as the standard engine governor except it cannot cut off fuel to the idle jet in the engine driven governor. This insures that if the converter tailshaft overspeeds it will not stop the engine. See Fig. 1-5.

Fig. 1-5 shows the position of the governor plungers under different engine and converter speed conditions.

Injectors

Fuel circulates through the injector at all times except during a short period following injection into the cylinder. From the inlet connection fuel flows down the inlet passage of the injector, around the injector plunger,

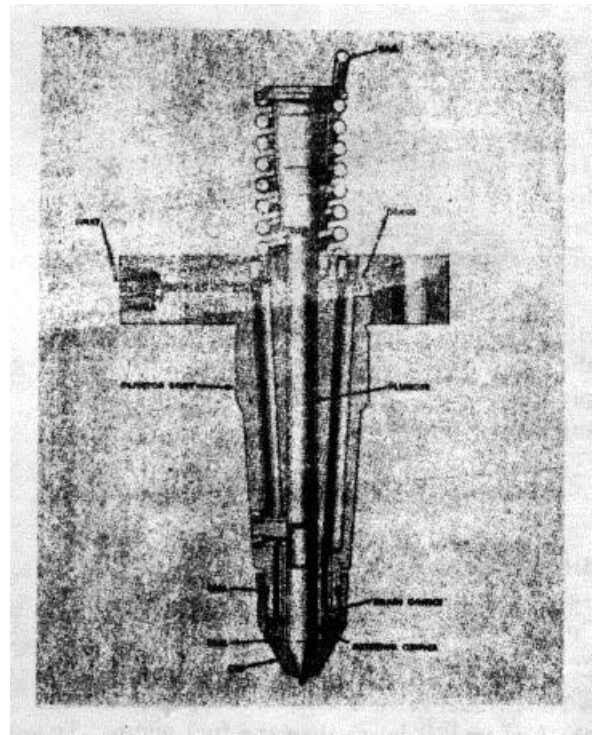
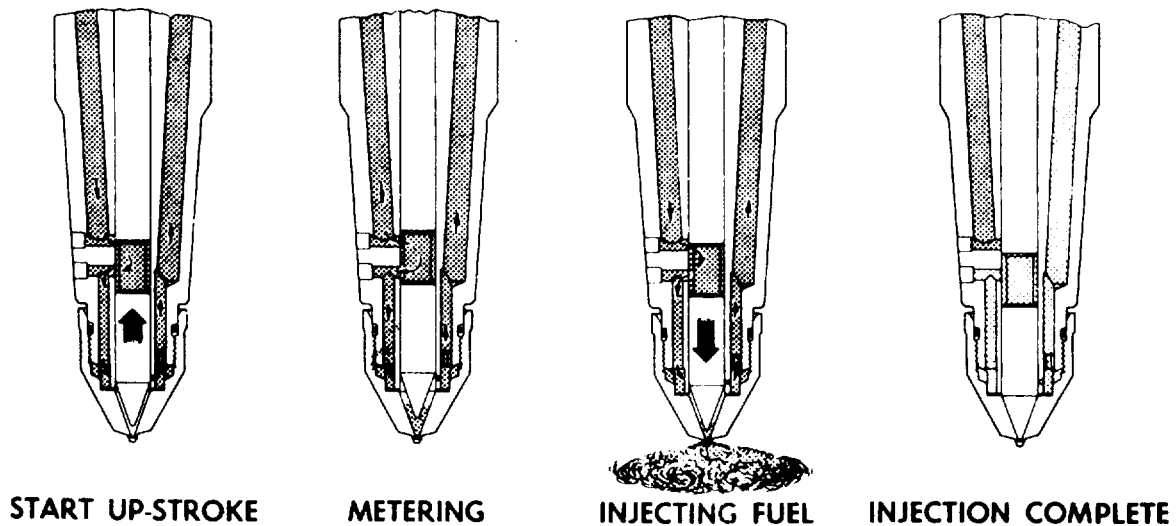

Figure 1-6. Injector cross section

between the body end and cup, up the drain passage to the drain connections and manifold and back to the supply tank.



As the plunger comes up the injector feed passage is opened and fuel flows through the metering orifice into the cup, at the same time fuel flows past the cup and out the drain orifice. The amount of fuel which enters the cup is controlled by the fuel pressure against the metering orifice. Fuel pressure is controlled by the fuel pump as previously described.

The plunger during injection comes down until the metering orifice is closed and the fuel in the cup is injected into the cylinder. While the plunger is seated in the cup all fuel flow in tile injector is stopped.

Supply Lines

SHUT-DOWN VALVE: There are two shut-down valves used on the PT fuel pump, a manual "push-pull" type and an electrically actuated valve.

The manual valve is used on fuel pumps where the fuel tank is lower than the fuel pump. To start the engine "push" in the valve cable knob; pull to stop. Keep the valve in the "out" position at all times the engine is not running.

The electric valve is always used where the installation has an overhead tank.

A manual over-ride button is provided on the forward end of the electric shut-down valve above the fuel pump. It allows the valve to be opened in case of electric power failure. To use, turn to right.

The engine can be shut down completely by turning off the switch key on installations with an electric shut-down valve. Turning off the key always stops the engine unless over-ride button has been locked in open position.

Valve can not be reopened by switch key until after engine comes to complete stop. If the key is turned "OFF", then "ON", while the engine is being pushed by its load (like a truck coasting downhill) the shut-down valve solenoid may burn out as it tries to open the valve against the built-up fuel pressure.

Never leave switch key or over-ride button in valve-open or run position when engine is not running. With overhead tanks this would allow fuel to drain into cylinders causing a hydraulic lock.

SUPPLY LINES: Fuel from the fuel pump must flow through lines to get to the injectors. These lines must be held to a specified size to insure an even pressure and supply of fuel to each injector. From the supply lines fuel enters the inlet connection to the injector.

INLET CONNECTIONS: The inlet connection connects the supply fuel manifold to the injector and contains a fine mesh screen at the large or cage end. This screen is the last protection against dirt entering the injector. There are no check valves in the inlet connection used in the PT fuel system.

DRAIN LINES: Not all the fuel entering the injector is burned in the cylinder. A set proportion circulates through the injector and is returned to the supply tank through the drain fittings, drain manifold and drain line. The drain lines must also be held to a specified size to prevent restrictions on the injectors.

SECTION II

Fuel System Installation

Changing Fuel Systems

The PT fuel system can be adapted to most Cummins Engines by making the changes described in the following paragraphs. The complete fuel system is changed including the fuel pump, inlet connections, fuel lines and injectors. Conversion parts are available to change the fuel pump drive or air compressor-to fuel pump drive coupling.

Parts described in this section can be obtained as listed in the PT Parts Book, Bulletin 6369.

FUEL PUMP: The fuel pump is a completely new unit which mounts to a bracket with three cap screws, lockwashers, and two dowels or in case of L, LR and NHH engines is flange mounted. The bracket in turn mounts over similar dowels as used for the DD pump bracket or Single-Disc fuel pump and is held in place with cap screws. It is not necessary to time the pump to the engine and timing marks are to be disregarded.

1. Assemble the bracket to the fuel pump.
2. Assemble the pump and bracket to the engine block, see "Drive Coupling."

INJECTORS: The injectors used with the disc-type fuel pumps must be replaced by a complete set of new injectors, especially designed for the PT fuel system. See Fig. 1-3.

1. The new injectors do not have a cover and thus the flange thickness is less than on the ones removed. The injector studs in the cylinder head must be changed or spacers used over the studs.

2. Clean the injector seat with a clean rag wrapped around a wooden stick. *Never use a screw driver or a metal tool for this operation; a scratched seat may cause a compression leak.*

3. Assemble the injectors in position. Fig. 2-1.

CAUTION:

BE CAREFUL NOT TO DAMAGE THE INJECTOR TIP.

4. Assemble the spacers, if used and injector

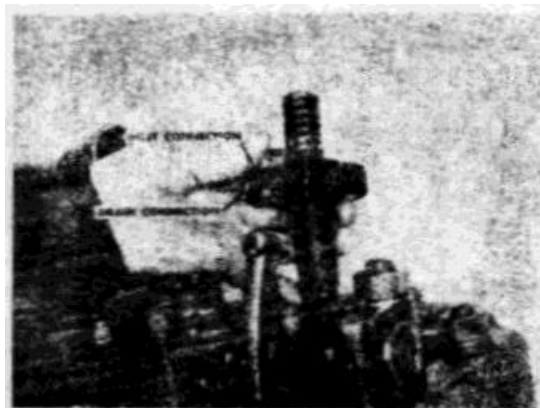

Figure 2-1. Assembling injectors

hold-down nuts over the studs, but do not tighten. Fig. 2-2.

5. Screw in the fuel inlet and drain connections about 3 or 4 turns. This is to align the injector body with the fuel connections so the connecting gaskets will seat squarely on the face of the injector. The old inlet connections must be replaced with new connections, see parts books for part numbers. Fig. 2-3.



Figure 2-2. Injector hold-down nuts

6. Torque the injector stud nuts in alternate steps of 2 ft. lbs. to:

- a. 0 to 8 foot-pounds for the J series engine.
- b. 10 to 12 foot-pounds for tile 11, Nil, VT and NVH series engines.
- c. 15 to 20 foot-pounds for L and LR engines.

7. Tighten the fuel inlet connections to 20/25 foot-pounds on all engines except the L and LR; tighten L and LR connections to 75 to 80 foot, pounds.

8. Make injector adjustments as outlined on Page 3-2.

FUEL MANIFOLDS: Inlet Manifold 1. The injector supply tubes are replaced with a fuel manifold. Fig. 2-3 The connecting point between the two sections also serves as a fuel inlet connection from the fuel pump on all engines except the JS. The JS uses a one-piece manifold with brazed connector. See "Fuel Piping Diagrams."

2. The line from the fuel pump shutoff valve to the fuel manifold must be 5/16 inch tubing. **It is essential that the proper size tubing be used throughout the complete fuel system to insure the proper flow of fuel.**

Drain Manifold: 1. The injector drain manifold is replaced with a new brazed manifold. Fig. 2-3.

2. A line must lead from the drain manifold to the top of the fuel supply tank. This must be No. 8 Stratoflex or equivalent hose. See "Fuel Supply Tank" and Figs. 2-9, 2-10, 2-11 and 2-12.

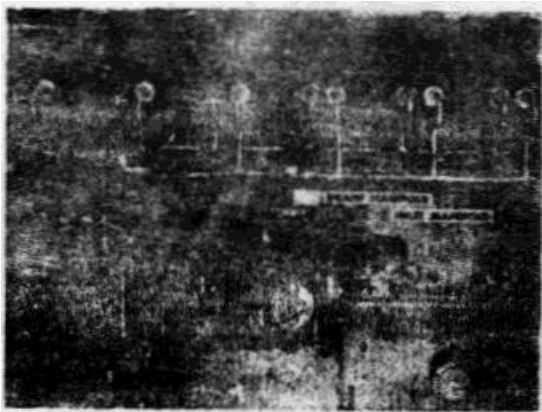

Figure 2-3. Inlet and drain manifolds

DRIVE COUPLINGS: The PT fuel pump is driven by a flexible rubber jaw-type coupling; adapter couplings are available to change spiders used on air compressors of drive units. This coupling requires shims to maintain the proper axial clearance between coupling halves.

1. Remove the old spider coupling and assemble the adapter coupling to the air compressor or drive shaft. Fig. 2-4.

2. Assemble the coupling half to the adapter coupling on the compressor or drive unit.

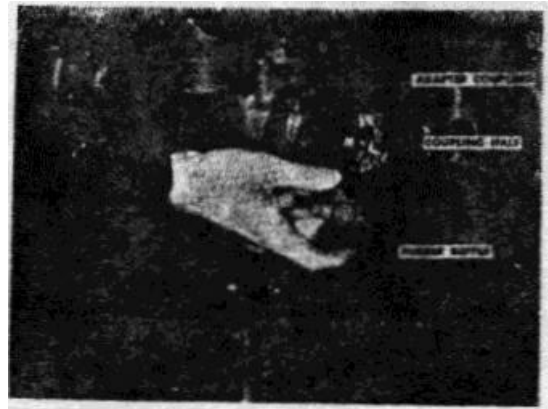

Figure 2-4. Coupling rubber buffer

3. Assemble the rubber buffer to the coupling Fig. 2-4.

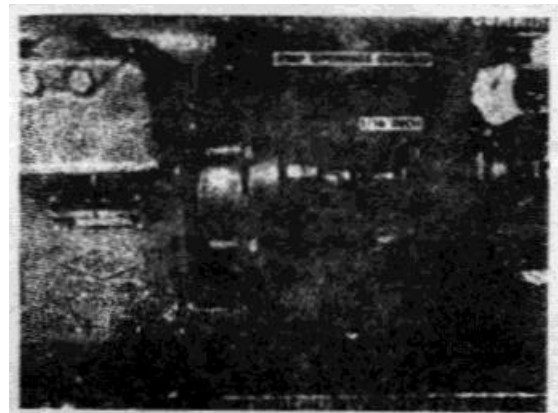

Figure 2-5. Coupling clearance

4. Mount the fuel pump and bracket to the cylinder block and measure the clearance between the coupling halves. Fig. 2-5. This clearance should be 1/16 inch. Clearance can be adjusted by adding or removing shims. Fig. 2-6.

5. Check the concentricity of the couplings, they must be concentric within .015 inch total indicated run-out. This can be regulated by adding shims between the fuel pump and bracket. Fig. 2-7.

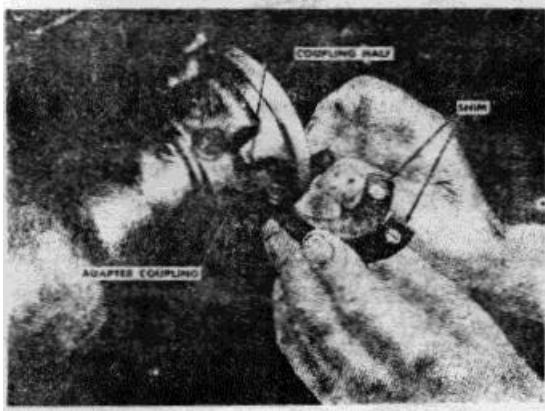

Figure 2-6. Adding shims to coupling

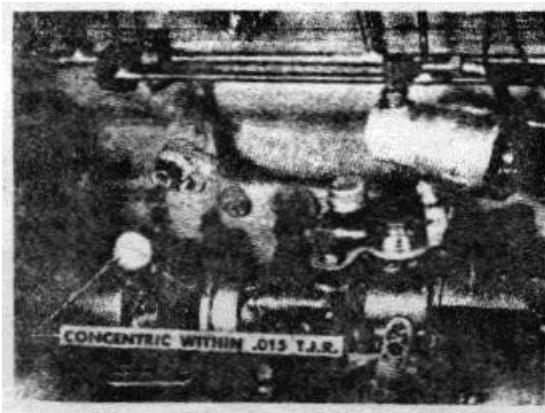

Figure 2-7. Checking coupling concentricity

6. Remove the fuel pump and bracket, add shims if required, and then mount the pump back on the engine.

FUEL SUPPLY TANK: The fuel supply tank with this fuel system serves a dual purpose. First it contains the fuel supply and; second it acts the same as a float chamber on other Cummins fuel systems, i.e., it receives fuel from the injector drain manifold. Fuel which circulates through the injectors carries heat from the injectors back to the tank. Under cold weather conditions this heated or warm fuel will aid in prevention of frozen fuel lines.

The following tank and piping instructions refer to Figures 2-9, 2-10, 2-11, 2-12, 2-13, and 2-14 shown on succeeding pages:

1. Venting arrangements shown are representative of conditions required for separation

of liquid and fumes coming from the return lines to the tank. In installation where the use of an "air dome" is necessary, an additional vent must be provided as shown in Fig. 2-11. This air dome must be at least 5 inches high and 2 1/2 inches I.D. A vented filler spout of size equal to the air dome may be used provided the vent hole is 1/8 inch in diameter. Air vent must be below level of injector in all cases except where an overhead tank is used.

2. To avoid overflow of fuel in hot weather the fuel tank should be designed so it will hold only 95% of its total capacity.

3. The fuel filter should be readily accessible and should be located level with or higher than the fuel pump to facilitate starting. It is best to locate the filter under the hood for cold weather operation.

4. Make sure all suction line connections to the pump are air tight, with the outlet from the tank in the center and 3/4 inch above bottom of tank. This may be a bottom connection or a pipe from any location reaching to the bottom center of the tank.

5. The injector drain connection in the tank should be located near end of the tank above surface of the fuel and separated from the suction inlet by at least 12 inches.

6. A sump should be provided in the tank to drain sediment and water. See Fig. 2-14.

7. For installations which are subject to I.C.C. regulations, it is recommended that fuel line or vent location and protection be made to conform with I.C.C. specifications.

8. An overhead tank installation should be used under any condition where fuel might possibly syphon back to the injectors.

9. In any installation the tank location should:

- a. Not be more than 8 feet above the pump.
- b. Bottom of tank must not be more than 8 feet below the pump.

10. External connections must not extend more than 3/4 inch below bottom of the tank.

FUEL LINES: Following is a table of line sizes for different engines and the various locations: See Fig. 2-8 and pages 2-4 and 2-5.

Line Location	Engine-Line Size 4, 6 or 12 cylinder
Supply tank to filter	No. 10 Stratoflex or equivalent
Filter to pump	No. 10 Stratoflex or equivalent
Drain manifold to supply tank	No. 8 Stratoflex or equivalent
Fuel pump drain to supply tank	No. 6 Stratoflex or equivalent
Supply tank top equalizer line	No. 8 Stratoflex or equivalent
Supply tank bottom equalizer line	No. 10 Stratoflex or equivalent

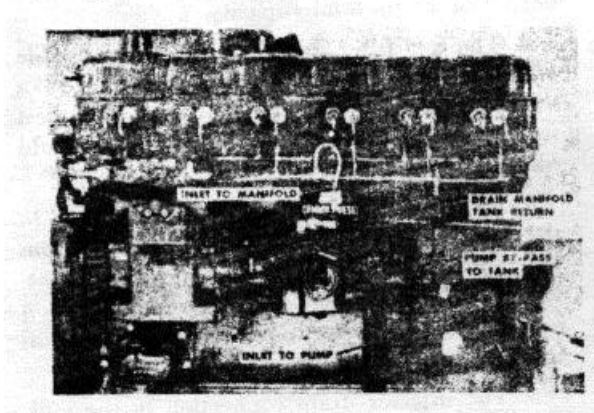

Figure 2-8. Complete fuel system-line hook-up

SHUT-DOWN VALVE: The shut-down valve used on the PT fuel system shuts off the fuel supply to the injectors and must be used to stop the engine. *The valve must be left in shutoff position when the engine is not operating.*

We recommend that you encase the manual shut-down valve cable in copper tubing, even if it has the flexible cover, to prevent sharp bends, dirt, etc., from interfering with cable operation.

TACHOMETER CABLE: The tachometer drive is a standard SAE size operating at 1/2 engine speed. Fill the cavity with clean, heavy grease before attaching the cable. Do not force tang into slot. If the fit is incorrect, change the tang to a new, standard SAE type.

SADDLE TANKS: See Piping Diagrams. When saddle tanks are used, equalizer lines must be connected between them of not less than No. 10 Stratoflex or equivalent hose. Failure to do this will result in running one side full and the other side dry. The suction line to the filter and pump should be installed with a tee fitting between the tanks.

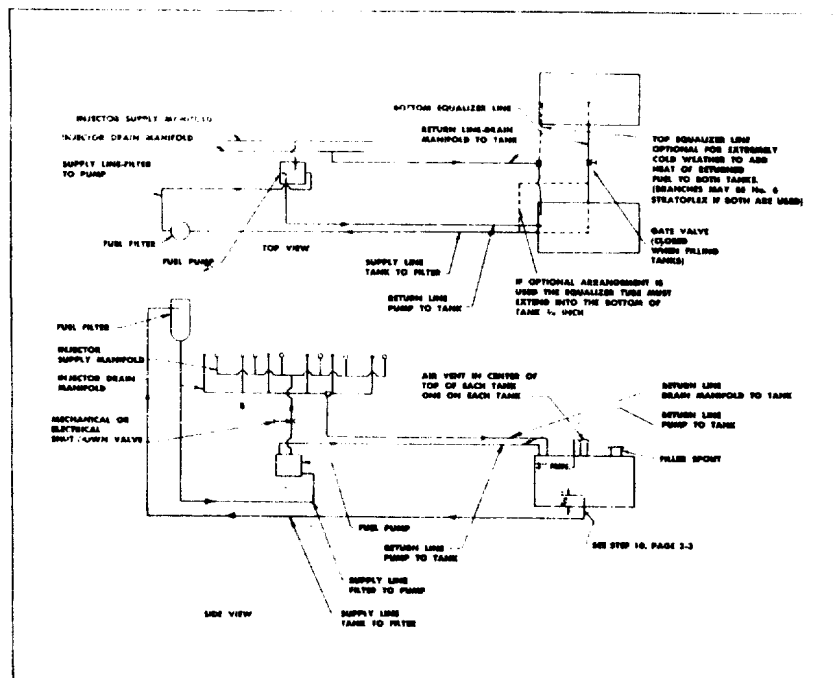

Figure 2-9. Installation with side tanks

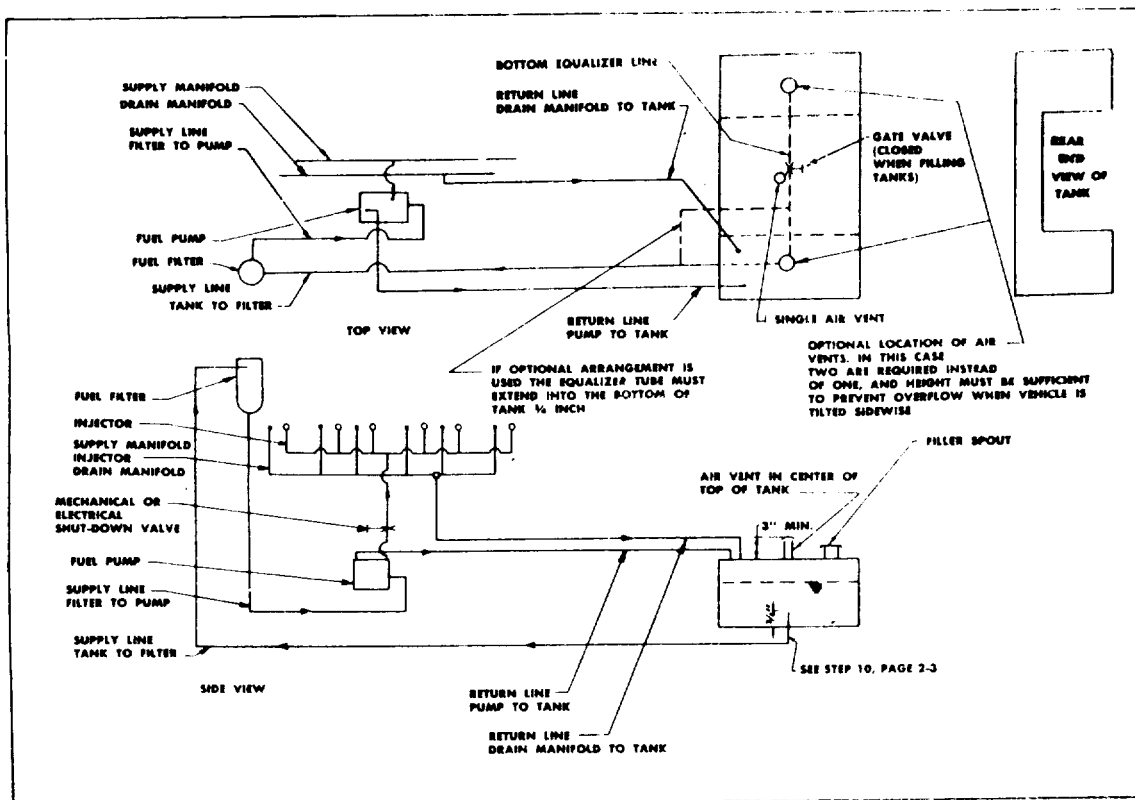

Figure 2-10. Installation with flat saddle tanks

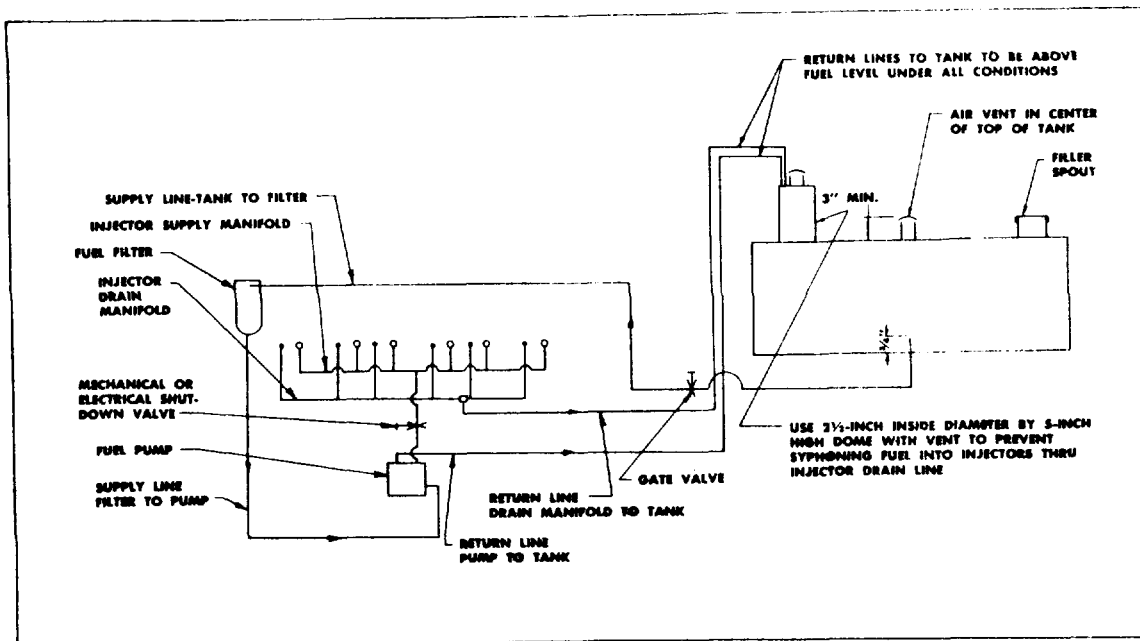

Figure 2-11. Installation with overhead tanks

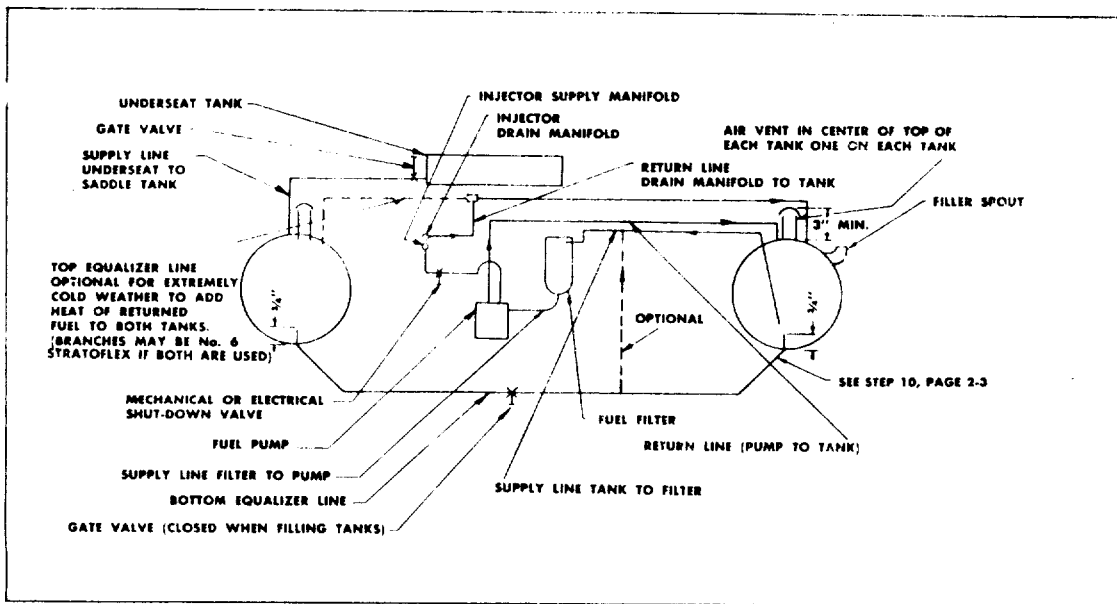

Figure 2-12. Installation with side and under seat tanks

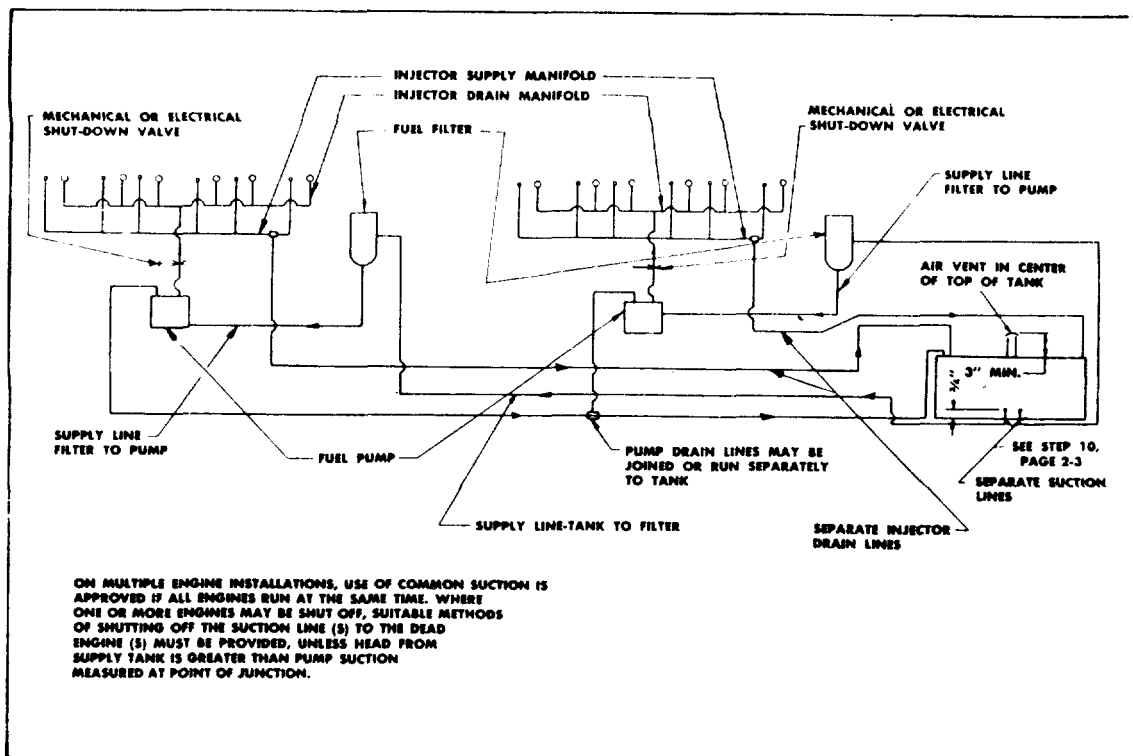

Figure 2-13. Typical dual or multiple engine installation

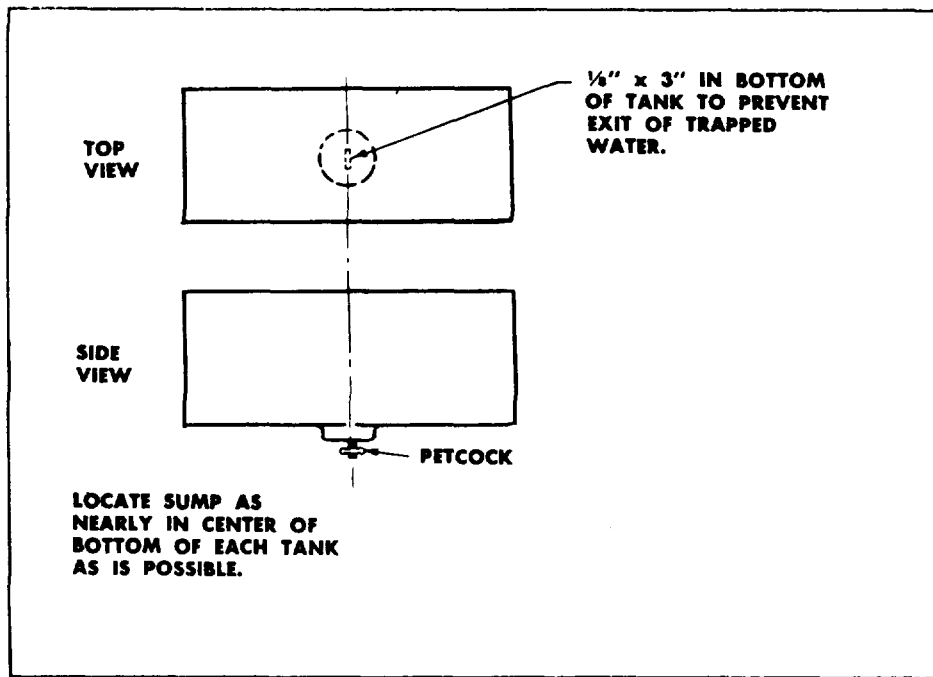

Figure 2-14. Recommended drain sump in tank

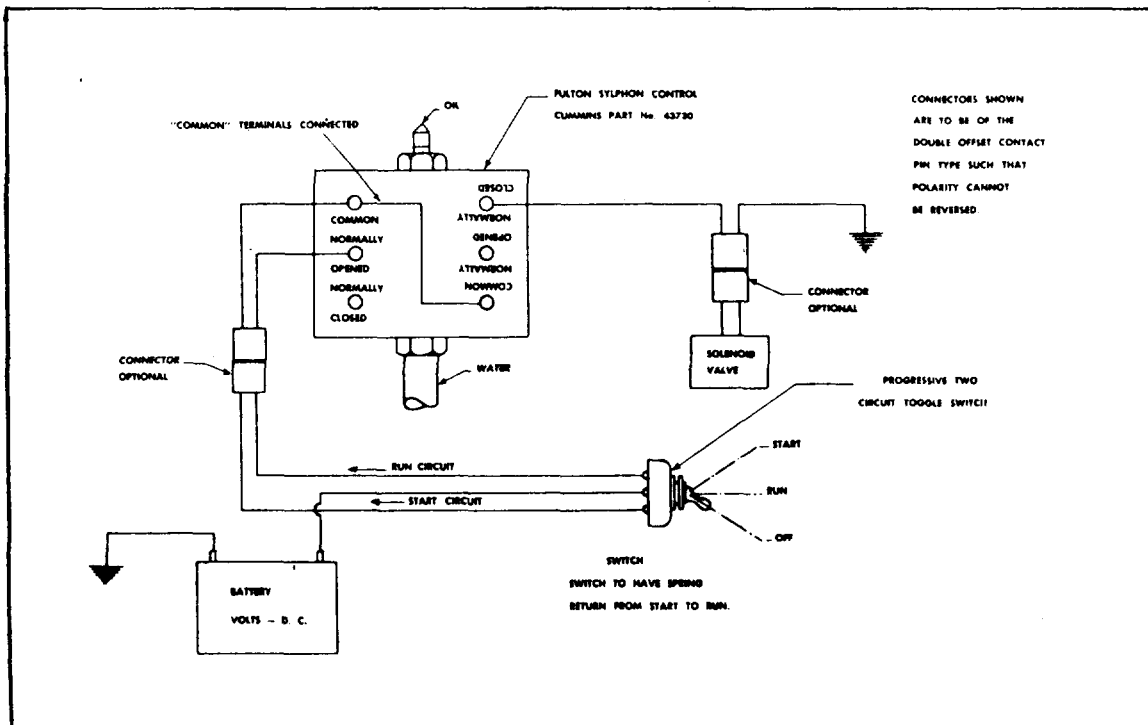

Figure 2-15. Wiring diagram electric shutdown valve with air starting system

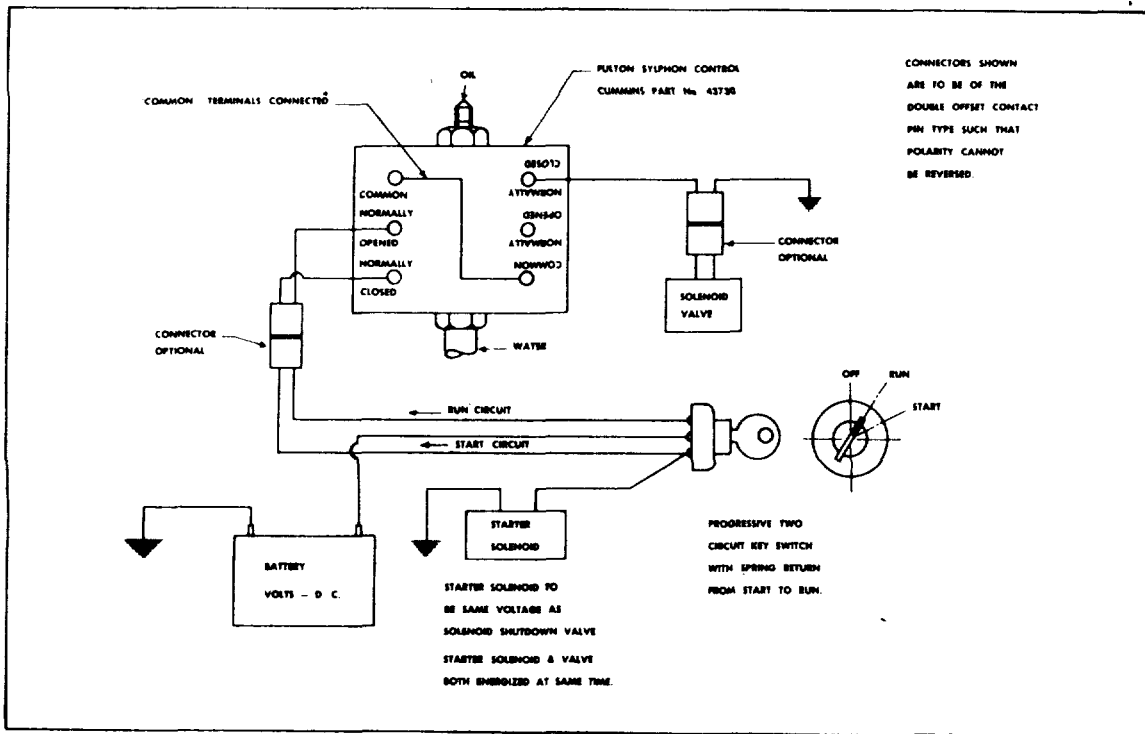

Figure 2-16. Wiring diagram electric shut-down valve with electric starting system

SECTION III

Fuel System Service and Adjustments

CLEAN FUEL PUMP SCREEN: The fine mesh fuel filter screen, in the fuel pump, should be removed and cleaned each 1000 gallons fuel consumed to prevent unnecessary wear and loss of power. A clogged filter screen will cut down fuel delivery to the engine. It is good practice to clean this filter after approximately 5 to 6 hours operation when the fuel pump is first put into service.

This is to remove particles of gasket cement which may have been used in connections between the pump and engine fuel filter.

The filter screen is located under the large cap on the top of the fuel pump. See Fig. 3-1. It can be removed by loosening the cap and lifting out the spring and screen assembly. The screen can be separated from one of the screen retainers for easy cleaning, the other retainer is soldered to the screen. Replace the screen and retainer (the retainer with the hole goes down) after cleaning.

The spring is assembled on the screen assembly, the cone end of the spring may be assembled either up or down. Cap must be tightened to 20/25 ft. lb. with a torque wrench; excessive tightening is not required.

PRIMING THE PUMP: No priming is required under normal conditions; however, the first time a "dry" pump is hooked up a few squirts of clean lubricating oil in the gear pump will aid in quicker pick up of fuel.

FUEL FILTER ELEMENT CHANGES: The majority of low power complaints are caused by dirty fuel filter elements. A dirty element restricts fuel flow in varying degrees and may stop flow altogether.

The element must be changed as often as necessary to maintain a full fuel flow. The change periods will vary according to the fuel used but the average is once every 400 to 500 hours.

1. Loosen the hex capscrew at the top of the fuel filter and lower filter case from top cover.
2. Take out the dirty element, clean the filter case, and install a new filter element. Fig. 3-2.
3. Install a new filter cover gasket, dip gasket in fuel oil before you install it so the cover will seat smoothly.
4. Fill filter case with clean fuel for faster pump pick-up and tighten cover capscrew securely to prevent air leaks.

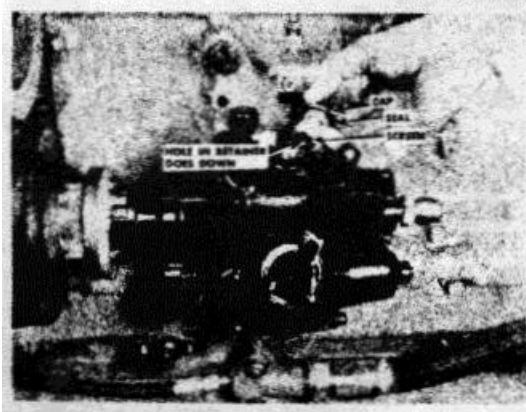

Figure 3-1. Replacing the filter assembly

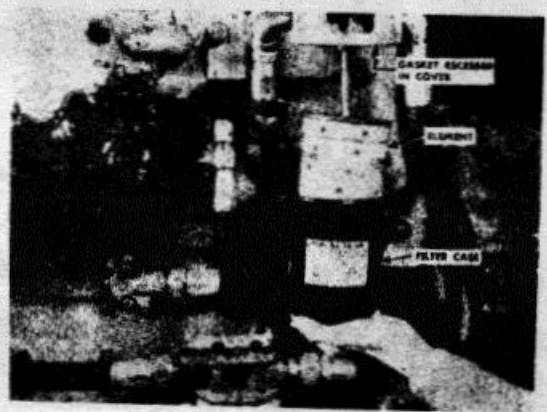

Figure 3-2. Change filter element

INJECTOR ADJUSTMENT: 1. Proper injector adjustment is more important on PT injectors because they perform the dual function of metering and injection. It takes only one misadjusted injector to make the engine miss. The "miss" may occur in that or another cylinder.

2. Injectors set too tight deflect the assembly and decrease fuel delivery even though manifold pressure will increase.

3. Loose injector settings increase fuel delivery and promote build up of carbon. Loose settings are often due to making adjustments on an engine that is too hot (oil temperature above 160°F.).

4. False injector adjustments may be due to:
- (a) Carbon inside cup, or on end of plunger.
 - (b) Dirty injector seats on cup or in copper sleeve.
 - (c) Binding adjusting screws.
 - (d) Binding rocker levers.
 - (e) Inaccurate torque wrenches.
 - (f) Cold settings. Always make a final setting of injectors on a warm engine. Set as follows:

Engine Series	Preliminary Setting @ 70°F. Oil Temp	Final Setting @ 140/160°F. Oil Temp.
J, JS, JT	4 ft. lb.	5 ft. lb.
H, NH, NVH, VT	5 ft. lb.	6 ft. lb.
L, LR	9 ft. lb.	11 ft. lb.



Figure 3-3. Adjusting injectors

5. Always readjust injectors on an engine after warming up -with oil temperature at 140°F. to 160°F. before you adjust fuel delivery or pressure settings of pump. Never release an engine for service without resetting injectors.

Governor Adjustments

STANDARD HIGH-SPEED GOVERNOR: High Speed Adjustment: Maximum engine speed is adjusted by adding or removing shims under the high-speed governor spring. Normally, this adjustment is made on the fuel pump test stand as the fuel pump is calibrated.

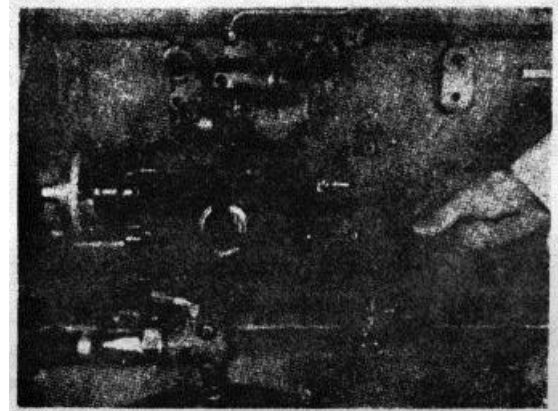

Figure 3-4. Setting idling speed

Idle Speed: 1. Warm engine up to 140°F. oil temperature, then shut-off or let it idle.

2. Remove pipe plug from spring pack cover. Fig. 3-4.

3. The idle adjustment screw is held in position by a spring clip. Turn screw in to increase, or out to decrease the speed. Idle speed should be set 40 to 50 rpm lower than desired if the adjustment is made with the engine running. With the engine running air collects in the spring pack housing and speed change results when the housing fills with fuel.

4. Replace pipe plug.

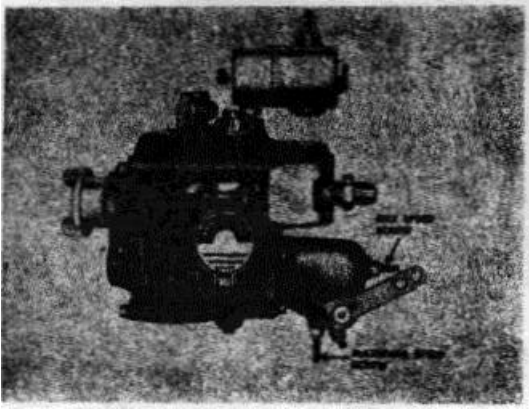

Figure 3-5. Adjusting screws, variable speed governor

VARIABLE-SPEED GOVERNOR: Both the maximum and idle adjusting screws are located on the governor cover. To adjust:

1. Loosen the adjusting screw lock nut.
2. Screw adjusting screw in or out to get speeds required. Fig. 3-5.
3. Tighten adjusting screw lock nut.

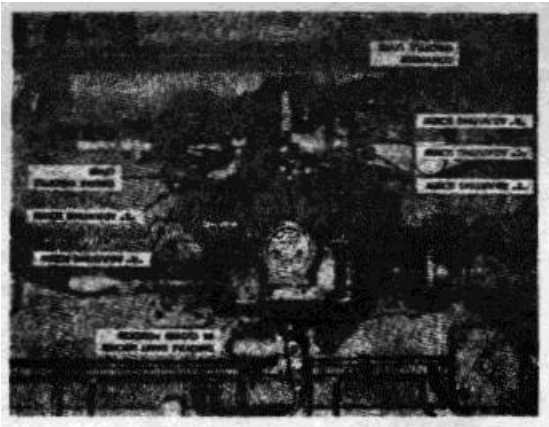

Figure 3-6. PT Pump with torque converter governor

PT TORQUE CONVERTER GOVERNOR: 1. Disconnect the torque-converter governor flexible drive cable or declutch the converter from the engine so the engine governor will have complete control of the engine. Disconnect the drive cable at the converter to prevent the cable from whipping.

2. Hold the converter lever in clockwise position and turn in converter governor idle screw "C" (Fig. 3-6) until you are sure the spring is compressed. Turn adjusting screw out; then, back in slowly to check this adjustment.

3. Start the engine and rotate the engine governor lever in a clockwise direction; then, set engine idle speed by adjusting the idle screw "A" to get 515 to 700 rpm. See Fig. 3-6.

4. Set approximate engine maximum no-load speed by adjusting maximum speed screw "B" while holding engine governor lever against its stop; turn lever in counterclockwise direction. See Fig. 3-6.

5. Stop the engine and engage the torque-converter clutch or connect the flexible drive cable to the torque-converter governor. Make sure that engagement is made so that the torque converter drives the governor. The flexible cable should have 10' radius bends, or larger, for satisfactory service life.

6. Start the engine and bring speed up to 1000 rpm with engine governor lever.

7. Advance speed of engine until engine speed reaches rated speed of converter tailshaft.

8. Decrease speed at torque-converter governor by adjusting screw "C" (out) until converter speed can be controlled by the converter governor lever; turn lever in a counterclockwise direction.

9. Advance engine governor to maximum speed position.

10. If the unit has a single speed setting:

- A. Adjust screw "C" to get rated no-load tailshaft speed of converter (Fig. 3-6).
- B. Adjust screw "D" until converter governor lever is locked in place. (Fig. 3-6).

11. If the unit has a two speed setting:

- A. Adjust screw "C" to get no-load tailshaft speed of converter. (Fig. 3-6).
- B. Adjust screw "D" until you reach maximum converter speed desired. (Fig. 3-6).

Adjustments for Minimum Fuel: 1. Operate the engine at full speed, no-load, with tailshaft governor in operation.

2. Loosen screw "C", Fig. 3-6, and back out approximately 3/4 inch.

3. Move the converter governor throttle lever counterclockwise until engine speed is reduced to 400 rpm. Hold in this position.

4. Loosen screw "E" and turn clockwise approximately 1/16 inch, until engine speed begins to increase 450 rpm.

5. Lock screw "E" in position and readjust screw "C" as described previously.

Stall Speed Settings: Where a given speed is important with converter output shaft stalled, check as follows:

- A. Stall the converter and check the engine speed.
- B. If engine rated speed is excessive adjust the engine-governor maximum-speed adjusting screw "B", or if governor adjustment does not affect the unit, decrease fuel delivery.
- C. If engine speed is low, adjust the engine governor maximum-speed adjusting screw "B" or if the governor adjustment does not affect the unit, the fuel delivery must be increased. Check fuel delivery on a pump test stand.

Changing Speed-Droop Converter Governor: Due to the variety of applications, converter ratios and operator preference for different operating characteristics the converter governor spring furnished in the fuel pump may not give the desired speed droop. Speed droop is controlled by changing springs; the springs listed below give a full droop range, the top spring gives the most droop and those below correspondently less.

CONVERTER GOVERNOR SPRINGS

<i>Part Number</i>	<i>Color Code</i>
109690	Pink
109689	Gray
109688	Brown
70822	Green
109687	Yellow
109686	Blue
70821	Red
107787	Red and Blue
101002	White
110461	Purple
110460	Orange
105422	Black

Adjustments For Unstable Speeds: 1. Start with minimum output shaft speed setting; then, loosen pump throttle screws and adjust so the throttle shaft turns in counterclockwise direction until engine speed increases 10 to 15 rpm. Continue throttle screw adjustment one-half turn of screws or approximately 10 to 20 rpm more and lock in place.

NOTE:

Make this check with a hot engine only.

- A. If throttle leakage is too high, the engine speed will tend to overspeed after the load is released and engine rpm will stay up.
 - B. If throttle leakage is too low, the engine speed will surge or be unstable at half or no-load.
2. If necessary readjust converter-governor speed-adjusting screws as described in steps 10 or 11 (Page 3-3) to get maximum speed of the unit.

CHECKING A PT PUMP ON THE ENGINE: The best way to check pump settings is on a fuel pump test stand; however, where a test stand is not available, a pump can be checked on the engine. The most accurate check with the pump on an engine, is while operating at full-load and rated speed just before the governor

cuts in, using an engine dynamometer. In a vehicle, maximum pressure checks can be made by pulling up a hill in a gear which will slowly allow the engine to accelerate to governed speed. A less accurate method is to operate the engine at 400 rpm below governed speed, then accelerate the engine to full throttle and check the maximum pressure indicated on the gauge.

Use ST435 pressure gauge to take manifold pressure readings and ST434 suction gauge to check the suction side of the gear pump. Always make sure injectors are adjusted properly before making pressure checks on the fuel pump. Loose injector settings will cause a low fuel pressure; likewise, tight settings result in high fuel pressure. Use gauges as follows:

1. To check maximum manifold pressure, connect ST-435 to the pump shut-off valve. Remove the pipe plug from the shut-off valve to connect the pressure gauge line. At governed speed (just before the governor cuts in) the maximum manifold pressure should be as listed under "Maximum Manifold Pressure" in table on Page 4-20 or 4-24.

2. Adjust the maximum manifold pressure by adding or removing shims from under the nylon fuel adjusting plunger in the by-pass valve plunger. Take care not to lose the small lockwasher which fits between the fuel adjusting plunger and the plunger cap.

3. To check inlet restriction connect ST-434 to the inlet side of the gear pump using the special adapter furnished with ST-434. When inlet restriction reaches 8 to 8.5 inches vacuum a fuel filter element change should be made or other sources of restriction removed. The engine will lose power when the restriction is greater than 10 to 11 inches vacuum.

4. Always make the above checks on a hot engine and operate engine for a minimum of five minutes between checks to clear system of air.

CLEANING PT INJECTORS BY REVERSE FLOW ON THE ENGINE: Carboning of PT injector metering orifices restricts the fuel flow to the cups with a resultant loss in horsepower of the engine.

Carbon can be removed from the metering orifice by reverse flushing; it should be performed on a warm engine as follows:

1. Loosen all injector adjusting screws one turn front bottom or one and one-eighth turns from set position. Lock with the jam nut.

2. Start the engine and accelerate with maximum throttle from idling to high-idle 10 to 15 times.

3. Readjust injectors to standard settings.

The engine will be difficult to start with the loose injector setting: it will smoke badly and will be sluggish. Which the injector is set with the adjusting screw backed off, the metering orifice will not be closed during injection. Extremely high injection pressure will force some of the fuel to back-flow through the orifice and remove carbon deposits. This method is of particular value for solving low power complaints of vehicles on the road. It may prevent the necessity of removing a unit from service and thus save time and labor. If this method is not effective, remove injectors for cleaning as described on Page 5-1.

SECTION IV

Fuel Pump Assembly and Disassembly

The PT fuel pump is very simply constructed and by removing the front cover and the governor spring pack cover all units are accessible. Units and assemblies can be removed and replaced easily with new or rebuilt units. In this section, we are interested only with this type of repair and no attempt will be made to cover machining operations.

Most of the screws used in this fuel pump are fillister head machine screws; therefore, a minimum of tools are required.

DISASSEMBLY

Vise and Holding Fixture

Mount the fuel pump on a good holding fixture. By using the JS fuel pump mounting bracket, ST-302 Vise and ST-303 Holding Fixture can be used to hold pump. Fig. 4-1.

Shut-Off Valve

1. The shut-off valve assembly is located on top of the fuel pump. Loosen the locknut. Fig. 4-2.
2. Screw the valve and valve fitting from the pump body.

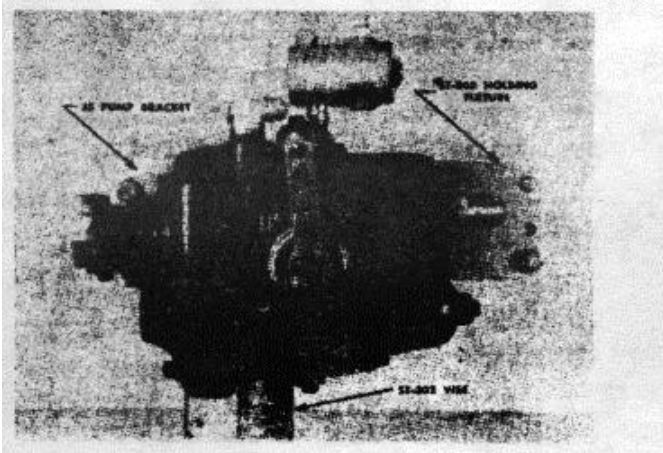

Figure 4-1. Fuel pump on holding fixture

3. Latest shut-off valves are flange mounted, remove capscrews and lift off valve and "O" ring.

Pressure Regulator

1. The pressure regulator is located in the back of the fuel pump and can be removed by using a 15/16" socket. The pressure regulator is just tight enough to seat the valve and should



Figure 4-2. Loosen shut-off valve nut loosen easily. Fig. 4-4.

2. Be sure to remove the copper washer on which the pressure regulator seats.

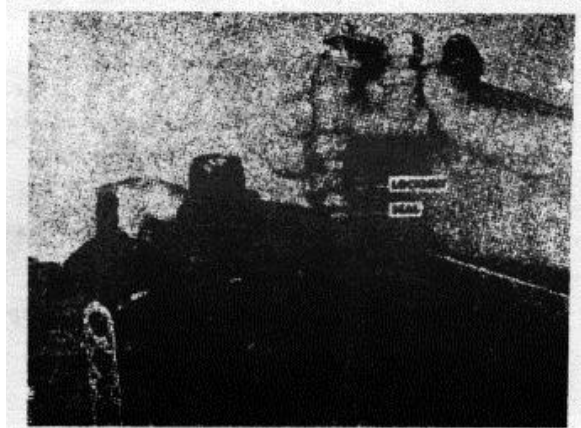

Figure 4-3. Remote shut-off valve



Figure 4-4. Removing the pressure regulator

Front Cover Assembly

1. The front cover assembly is held to the main housing by six fillister head screws and located by two dowels.

2. Remove the screws and plain washers.

Fig. 4-5.



Figure 4-5. Removing front door screws

3. Pull the front cover assembly and gasket from the dowel & A few taps from a plastic hammer may be required to loosen the cover.

CAUTION

NEVER USE A STEEL HAMMER ON ALUMINUM PARTS OR EXTENSIVE DAMAGE MAY RESULT.

5. Pull the cover assembly from the pump.

Fig. 4-6.



Figure 4-6. Remove the front cover



Figure 4-7. Remove governor plunger

Governor Plunger

Slide the governor plunger from its barrel to avoid accidentally dropping it Fig. 4-7. This plunger is a select fit to the barrel and a small burr could cause damage.

Throttle Shaft Assembly

1. Compress the nameplate retaining ring and disengage from its groove.

2. Pull the throttle shaft assembly from the fuel pump housing. Fig. 4-8.

3. Handle the throttle shaft with care to prevent damage to the surface. The shaft is a select fit in its sleeve.

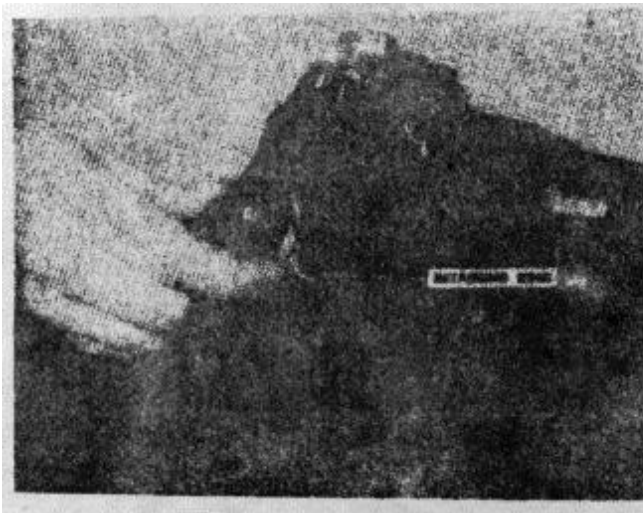

Figure 4-8. Removing throttle assembly

Gear Pump

1. Remove the four gear pump mounting screws.
Fig. 4-9.

CAUTION: Do NOT LOOSEN OTHER THAN THE FOUR MOUNTING SCREWS.

2. The gear pump and gasket may require a few taps with a plastic hammer to loosen. Do not use a steel hammer or damage will result.

3. Lift the gear pump from the pump main housing.
Fig. 4-10 and Fig. 4-11. There are two types of gear pump drives now in service and with minor changes they can be used interchangeably.

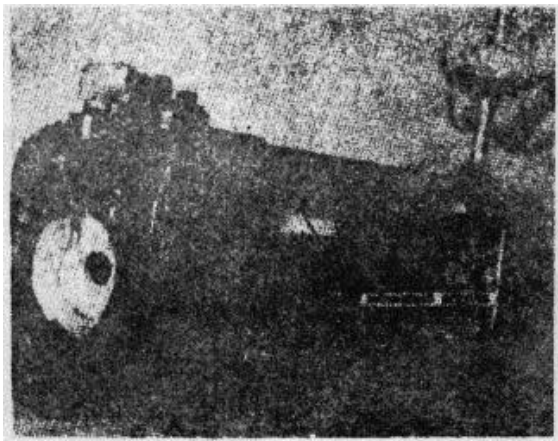

Figure 4-9. Remove gear pump mounting screws

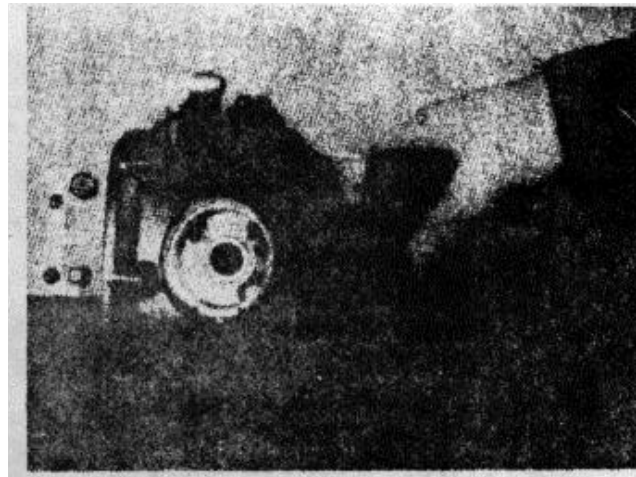

Figure 4-10. Removing the gear pump (A)

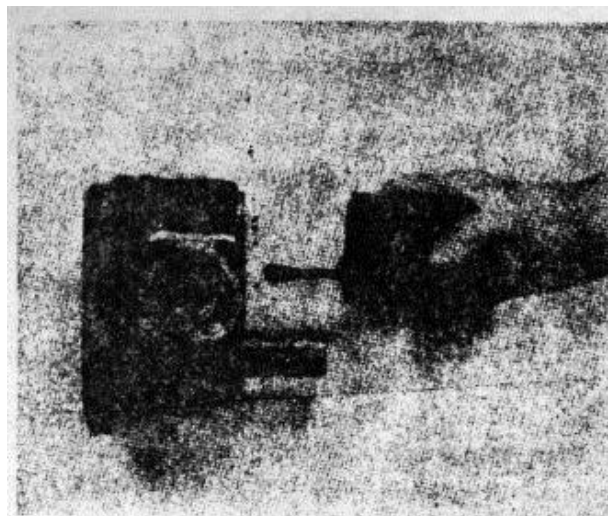

Figure 4-11. Remove the gear pump (B)

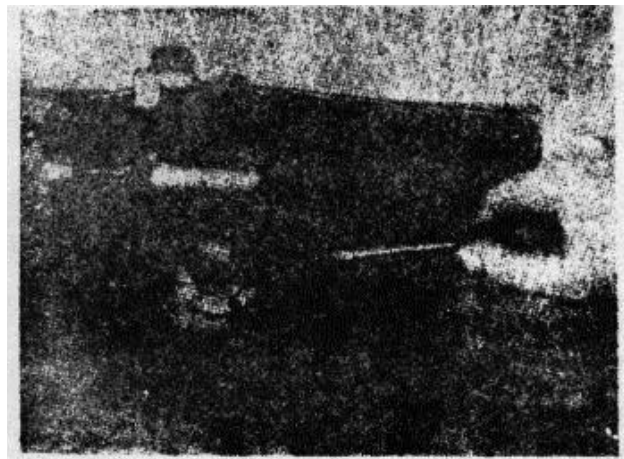

Figure 4-12. Removing the spring pack cover screws

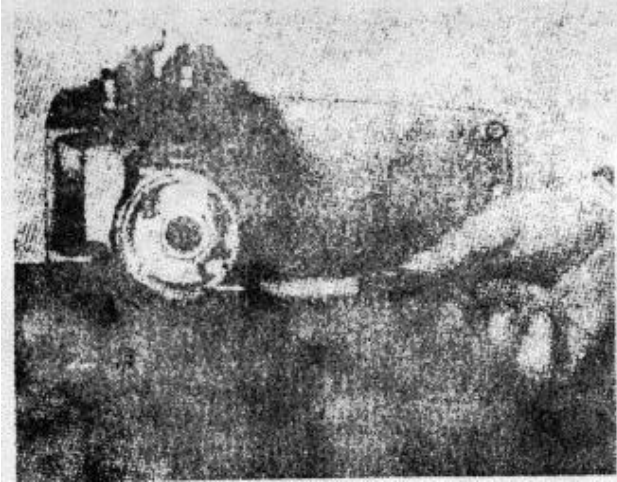

Figure 4-13. Remove spring pack snap ring

Governor Disassembly

The PT fuel pump may have either of two mechanical governors; a standard maximum speed governor, or a variable-speed governor.

MAXIMUM SPEED GOVERNOR: 1. Remove the four spring-pack cover screws and lift off the cover.

2. Use a pair of snap ring pliers and remove the spring-pack retainer snap ring.

3. Slide the high-speed spring, spring retainer and shims front the spring-pack housing.

4. Slide out the idle spring plunger guide, the two idle springs, and idle spring plunger.

5. Take care not to lose the idle spring rest washer.

VARIABLE SPEED GOVERNOR: 1. Remove the spring-pack cover assembly. Fig. 4-14.

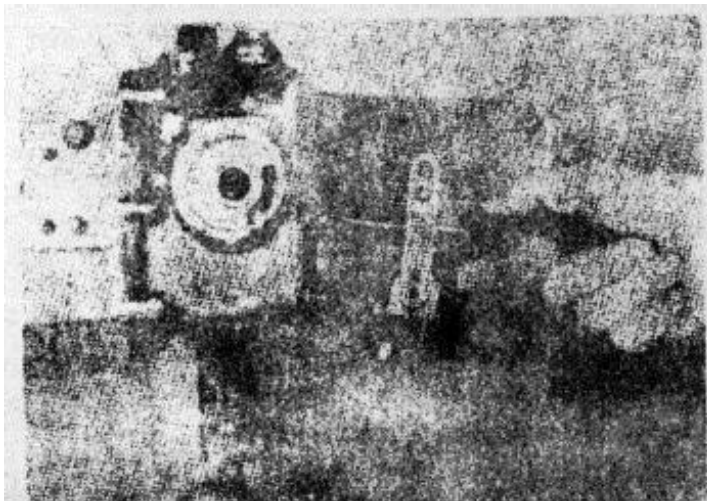

Figure 4-14. Remove spring pack cover

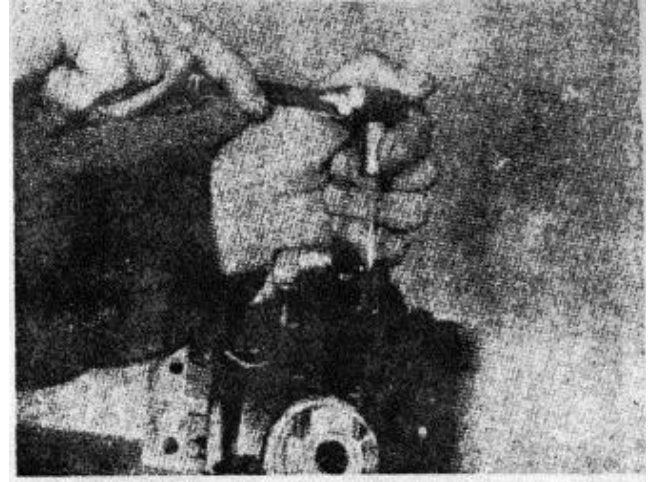

Figure 4-15. Loosening the filter screen cover

2. Slide the throttle lever plunger and governor spring from the pump and remove the snap ring from the spring-pack housing.

3. Remove the spring retainer, idle spring and governor spring plunger.

Filter Screen

1. Loosen the filter screen cover. Fig. 4-15.

2. Lift the cap, spring and filter screen assembly from the pump. The screen assembly is made up of a screen and two retainers. The bottom retainer has a hole in the center to permit fuel flow; this retainer is soldered to the screen.

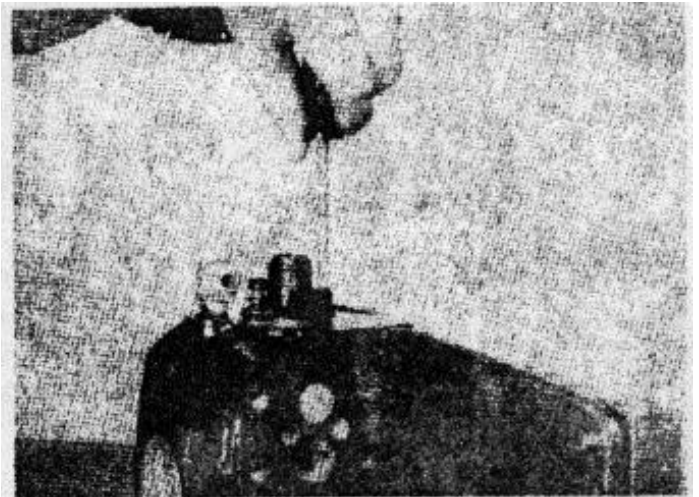

Figure 4-16. Removing tachometer cover screws

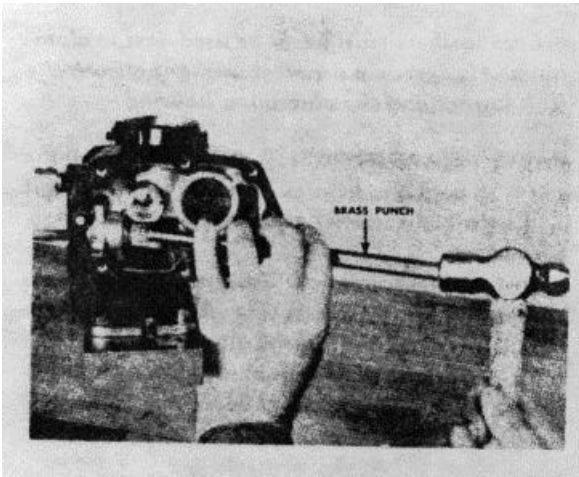

Figure 4-17. Loosening the tachometer drive in the housing

Tachometer Drive

1. Remove the tachometer drive cover screws. Fig. 4-16.
2. Lift the tachometer drive cover and gasket from the main housing.
3. Use a brass punch, and slowly and carefully drive the tachometer drive assembly from the pump housing. Fig. 4-17.
4. Lift the tachometer drive from the fuel pump .

The parts remaining in the main housing are subject to removal only if damaged and are covered under "Unit Rebuilding."

UNIT REBUILDING

The following information has been set aside from unit repair instructions because it is applicable to more than one unit or sub-assembly. In this section, we are concerned only with fuel pump sub-assembly repair and rebuilding.

Parts must not be discarded until they are worn beyond reasonable replacement limits:

All fuel pump parts will continue to function long after they show some wear. The mechanic who automatically replaces all wearing parts soon throws away good parts that are worth more than the wages of a good mechanic.

Parts that are worn beyond reasonable replacement limits must not be re-used:

The good mechanic quickly learns the "reasonable replacement limits," and then he uses all parts that will give another complete period of service without danger of failure. By a "period of service," we mean the same service period as set up for other engine unit replacements.

General Instructions

CLEANING: A clean shop, clean tools and good cleaning practices are essential to good quality fuel pump repair. Special care must be taken when cleaning aluminum alloy parts. Some cleaning solvents will attack and corrode aluminum.

Remember that time is seldom as important as a good job, and that cleaning time is always well spent. Most fuel pump failures occur because of dirt. Saving time by allowing dirt to cause another failure is always a waste of time.

INSPECTION: There are very few jobs in the shop that offer as many opportunities for saving parts and time as inspection. As little as five minutes spent on inspection may save several dollars worth of parts or prevent failure of the rebuilt pump.

Too often, inspection is regarded lightly and performed in a haphazard manner or not performed at all. Proper tools are essential to a satisfactory job of inspection.

TOOLS: Using proper tools has many advantages. From a safety standpoint, the proper tool will prevent damage to machined surfaces. Everyone

appreciates the light weight of the fuel pump. The light weight is made possible by the use of aluminum alloy parts, but aluminum is softer and more easily damaged than cast iron. Aluminum parts must be handled carefully.

All service tools are available from your Cummins Dealer.

An arbor press should be used for all pressing operations. Pressing is much better than driving for controlled pressure and alignment. Always make sure that the part is properly supported when pressing another part into it.

PRESSING LUBRICANT: -A good extreme pressure lubricant should be used on mating surfaces in all pressing or driving operations. The lubricant prevents galling or scoring during assembly and disassembly. Be sure to remove all burrs from mating parts before pressing them together.

NEEDLE BEARINGS: The thin surface-hardened outer-shell of the needle bearing acts as the hardened outer race surface, as well as a retainer for the rollers. After heat treatment, this shell may be out-of-round. It then becomes necessary to press the needle bearing assembly into a true round housing, and it must have an interference fit to restore the true round dimension necessary for efficient operation of needle bearings. Use a piloted mandrel and always press against the stamped end of the needle bearing.

Do not replace needle bearings unless inspection shows that it is necessary. As needle bearings are pressed in and out of bores, the bores enlarge and eventually it will be necessary to replace the housing. On the other hand, needle bearings are easy to replace and require no machining operations. If you use proper care and an extreme pressure lubricant, you should not experience any difficulty from replacing needle bearings in the few cases where it will be necessary.

Water or acid in the fuel will ruin needle bearings as well as other fuel pump parts.

CAPSCREWS AND WASHERS: Normally, in this pump as in all assembled units, capscrews have an engaging thread length two times the diameter. Observance of this rule will prevent stripping threads with a screw that is too short or breaking a part from using a capscrew that is too long.

Lock washers must never be used next to aluminum. Always use a us steel washer between the lock washer and the aluminum housing.

PARTS REPLACEMENTS: Always determine the need, if possible, before disassembling the unit and then replace only the parts which need replacement.

Instructions for complete disassembly and parts replacements are given in this section not because you will need to perform all operations on all pumps, or on any one pump, but only to supply you with instructions as you need them.

Main Housing

The drive shaft bushing, throttle sleeve, governor barrel and spring pack housing still remain in the fuel pump main housing.

The drive shaft bushing can be removed if damaged. The throttle sleeve and governor barrel are lapped to size during assembly to the housing and due to the close tolerances must be returned to the factory for replacement.

REAR DRIVE SHAFT BUSHING: 1. The rear drive shaft bushing should be replaced if worn beyond .4415. When new the bushing is assembled in position and it has a .4375/.4385 I.D.

2. If bushing replacement is required, it can be pressed out and a new bushing pressed in its place. Fig. 4-18.

3. Press the new bushing .210/.220 below the housing face.

4. New bushings must be line reamed to .4375/.4385 I.D. after assembly. Use ST-433

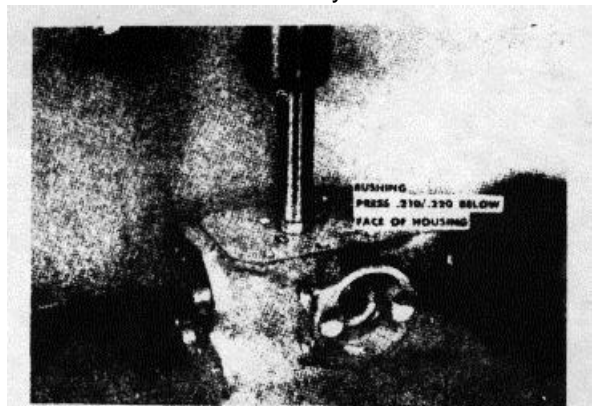

Figure 4-18. Pressing in a new rear drive shaft bushing

Fixture and ST-436 Reamer for this operation.

FRONT DRIVE SHAFT BUSHING: 1. The front drive shaft bushing should be replaced if worn beyond .7525 I.D. A new bushing has a .7495/ .7505 I. D.

2. Press the new bushing flush with the housing bore.

3. Line ream the new bushing to .7495/.7505 I.D. with ST-490 Fixture and a 3/4" reamer.

GOVERNOR BARREL AND THROTTLE SLEEVE:

The governor plunger and throttle shaft are select fit to the governor barrel and throttle sleeve.

If the governor plunger or throttle shaft are worn, use the next size parts. For example, replace a class "O" shaft with a class "1" shaft. Class sizes are stamped on the parts.

If the governor barrel or throttle sleeve are damaged or worn beyond a class "4" fit send the pump housing to the factory for repair.

Gear Pump There are two gear pumps used on PT fuel pumps. One is driven by a pin inside the drive gear. This gear pump cannot be rebuilt in the average shop. The other gear pump has a drive shaft; it can be repaired as follows.

DISASSEMBLY: 1. Remove the four screws and part the front cover, rear cover and center section.

2. If the gears are damaged press them off the shafts. Fig. 4-19.

3. Press out the needle bearings.

ASSEMBLY: 1. Press in new needle bearings so they are flush to .010 below the front and rear cover faces. Fig. 4-19.

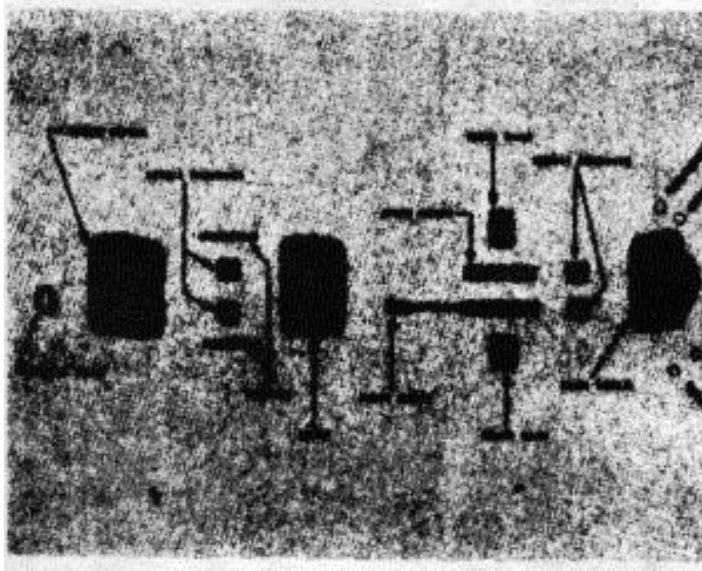

Figure 4-19. Gear pump assembly

2. Install new expansion plugs in the rear cover.
3. Press new gears on the drive and driven shaft until they are .680/.700 from the rear end of the shaft.

4. Install new gaskets on covers.

5. Slide the shafts with gears into the front gear pump cover, then slide the center section over the gears. Fig. 4-19.

6. Install the rear cover and fasten to rest of gear pump assembly with four capscrews.

7. As a final check see that pump turns freely and that drive shaft extends 2.412/2.370 from front cover.

Electric Shut-Off Valve

DISASSEMBLY: 1. Remove nut at rear of valve. Cap, coil housing, and coil can then be removed from valve body.

2. Use ST-481 nut spanner wrench and unscrew the sleeve assembly from the body. Fig. 4-20.

INSPECTION: 1. Check the coil to see that it is not burned out.

2. If the valve has been leaking at the flange tighten the sleeve assembly in the valve body or replace the plunger and seal assembly.

3. Check the soft inserts in the plunger for wear, if worn replace the plunger.

4. If the valve develops a loud buzzing noise, examine the sleeve assembly and plunger and remove any foreign matter imbedded in these parts.

CAUTION:

BE CAREFUL NOT TO DAMAGE THE SLEEVE SEAT. Do NOT CLEAN WITH ANT TYPE CLEANING FLUID.

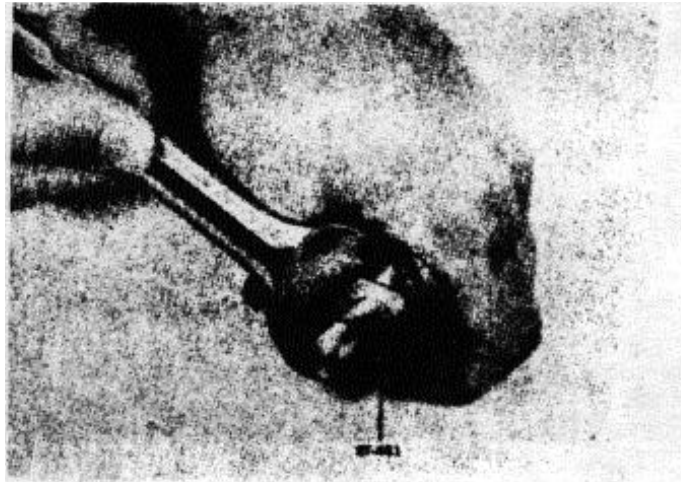

Figure 4-20. Removing sleeve assembly

ASSEMBLY: 1. Assemble in reverse order of disassembly described above.

2. Do not over tighten nut on coil housing or it will put an undue strain on the sleeve assembly.

Governor Plunger

DISASSEMBLY: 1. If the governor plunger thrust washer is worn it may be necessary to replace it.

2. Drive the retainer pin from the plunger.

3. Pull the governor plunger driver from the plunger.

4. Plungers are a classified fit and the proper size for the pump being repaired can be obtained by checking the class number on the governor barrel.

ASSEMBLY: 1. Assemble the plunger driver through the thrust washer and drive into the plunger. Fig. 4-21. The chamfered side of the thrust washer must face out or away from the

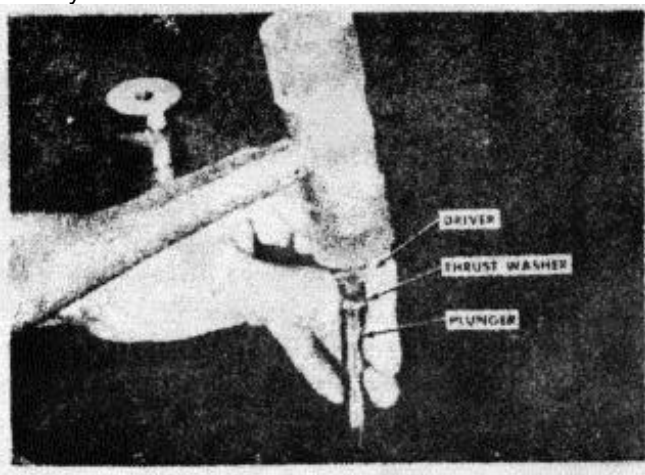

Figure 4-21. Assembling plunger and driver

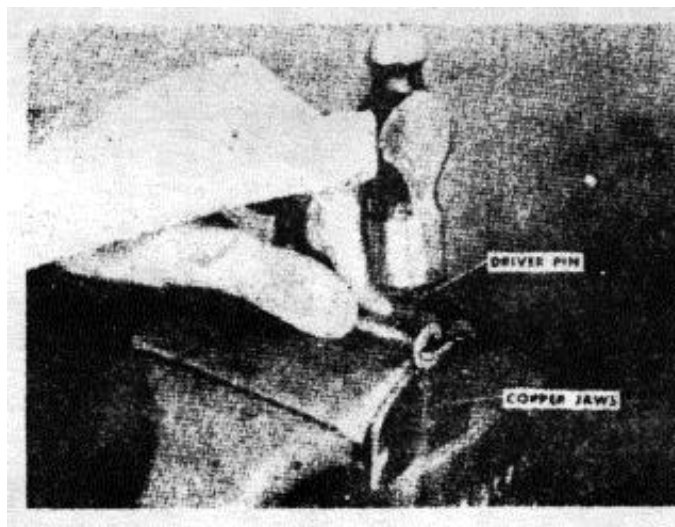

Figure 4-22. Driving in plunger retainer pin

plunger. The thrust washer is to be assembled with .002/.005 clearance between the washer face and driver so the washer "floats."

2. Drive the retainer pin through the plunger and plunger driver. Fig. 4-22.

CAUTION

THE PLUNGER HAS A LAPPED FINISH AND ASSEMBLY SHOULD BE MADE ON A COPPER JAWED VISE OR V-BLOCK TO PREVENT DAMAGE.

Tachometer Drive

DISASSEMBLY: 1. Remove the oil seal from the tachometer drive shaft. Fig. 4-23.

2. Press the tachometer drive shaft from the drive gear and bushing. Fig. 4-24.

3. The tachometer split-drive pin may be pulled from the tachometer drive shaft if necessary, by compressing the pin in a vise.

ASSEMBLY: 1. Assemble the bronze bushing over the tachometer shaft; cone end goes toward the drive gear end.

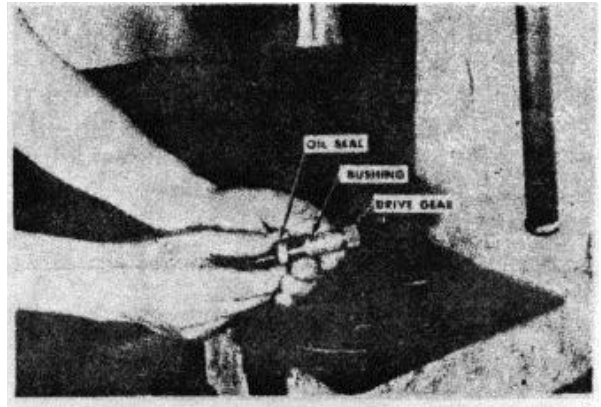

Figure 4-23. Remove oil seal-tachometer drive

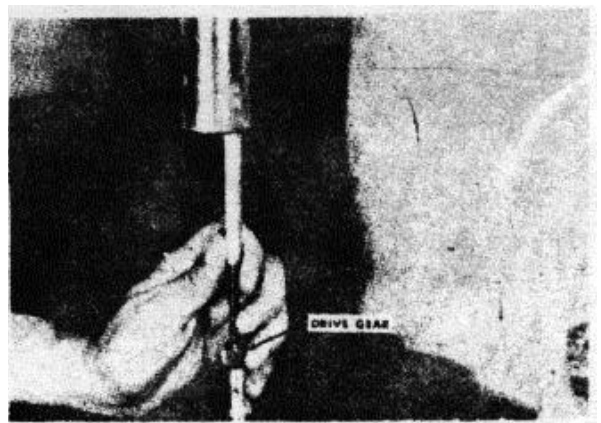

Figure 4-24. Removing drive gear and bushing

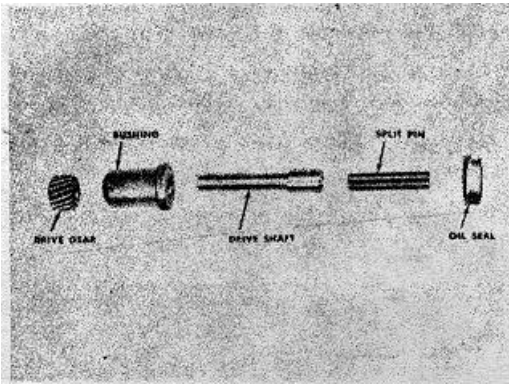

Figure 4-25. Exploded view of the tachometer drive

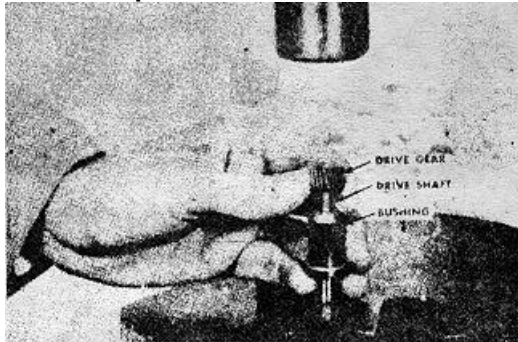

Figure 4-26. Assembling tachometer shaft assembly

2. Press the tachometer drive gear over the shaft until the gear is flush with end of the shaft and check to see the shaft turns freely in the bushing.

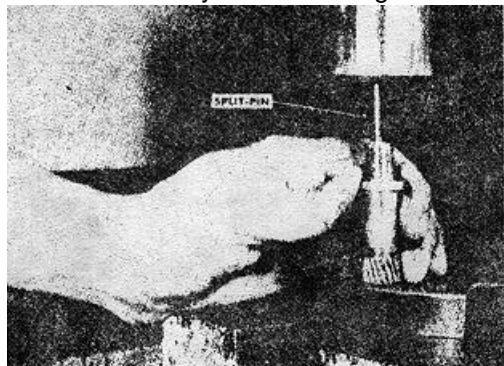

Figure 4-27. Pressing drive pin into position

3. If removed, press the tachometer split drive pin into the drive shaft. Fig. 4-27.

Front Cover Assembly

DISASSEMBLY: 1. Remove the fuel pump drive coupling retainer capscrew and washers. Fig. 4-28.

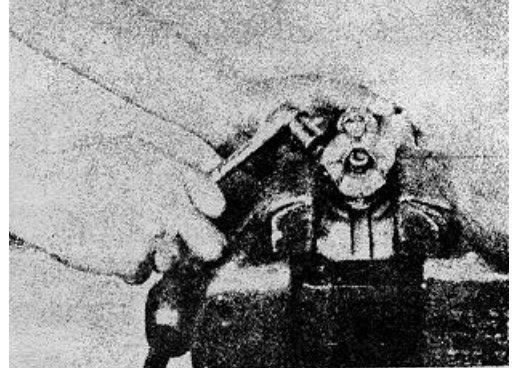

Figure 4-28. Remove coupling capscrew

2. Press the drive coupling from the drive shaft and remove the coupling key. Fig. 4-29.

3. Remove the drive bearing snap ring. It will not be necessary to remove the ring from around the drive shaft. Fig. 4-30.

4. Press the drive shaft assembly from the front cover.

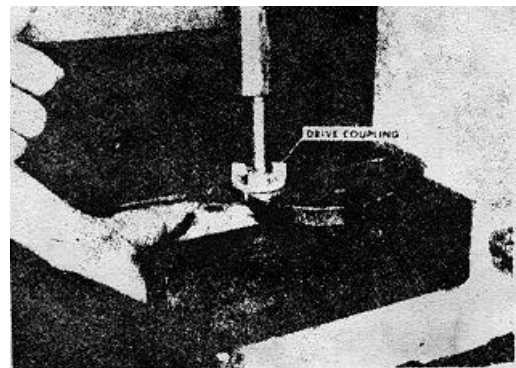

Figure 4-29. Removing drive coupling

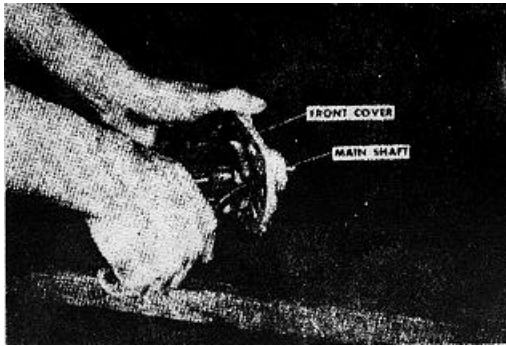

Figure 4-30. Remove snap ring

CAUTION: POSITION THE GOVERNOR WEIGHT CARRIER SO IT WILL ALLOW THE GOVERNOR DRIVE GEAR TO PASS.

5. Press the drive shaft oil seal from the cover. Fig. 4-31.

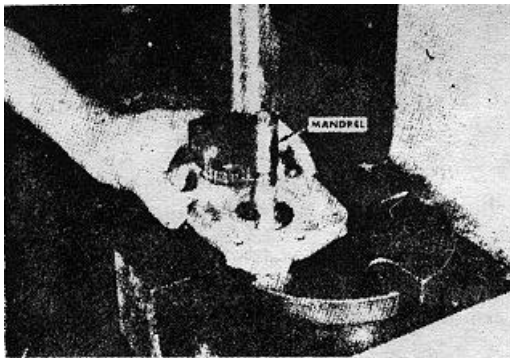

Figure 4-31. Press out the oil seal

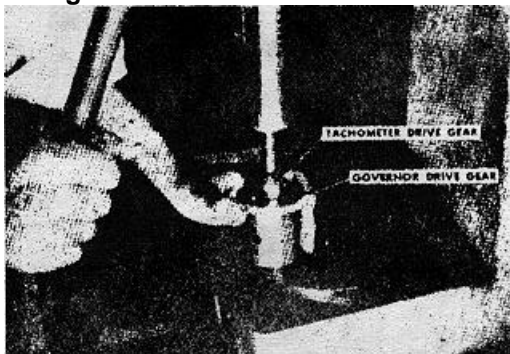

Figure 4-32. Pressing of drive gears

6. If the pump has an inside splined tachometer gear press out the drive gear pin.

7. Press the tachometer drive gear and governor drive gear from the drive shaft. Fig. 4-32.

CAUTION: PRESS WITH CARE TO AVOID DAMAGE TO DRIVE SHAFT.

8. Press the drive bearing from the shaft. Fig. 4-33.

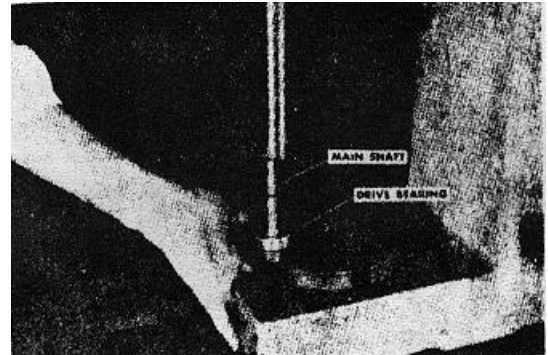

Figure 4-33. Pressing off the drive bearing

9. Remove the governor bearing lock screw and washer. Fig. 4-34.

10. Press governor assembly from the front cover. Fig. 4-35.

11. If necessary pull the governor bearing from its drive shaft.

GOVERNOR DISASSEMBLY: 1. The governor assembly can be disassembled to change the drive gear, bearings or governor weights.



Figure 4-34. Remove the bearing lock screw

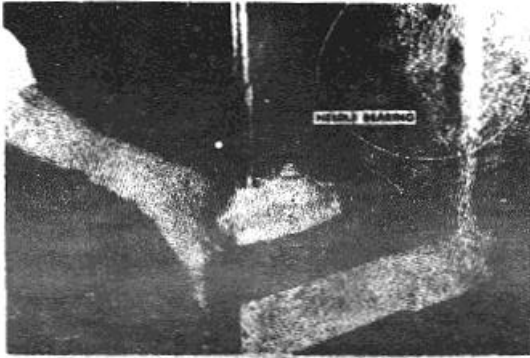

Figure 4-35. Pressing out governor assembly.

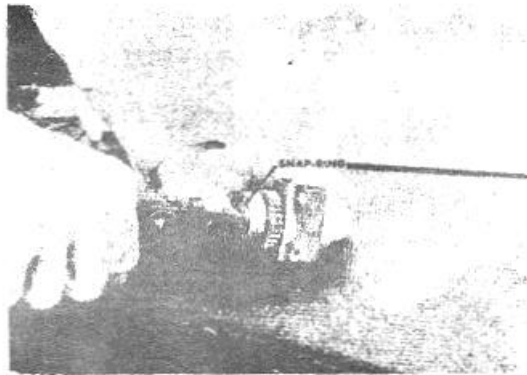

Figure 4-36. Removing bearing snap ring.

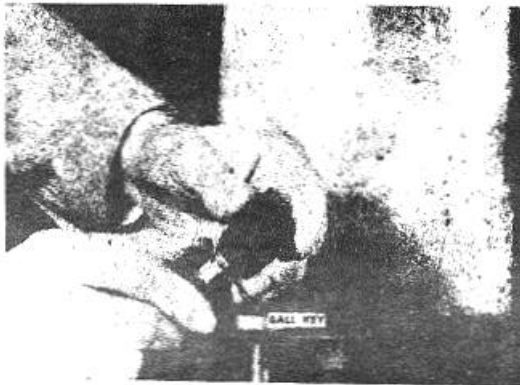

Figure 4-37. Assembling drive gear.

2. Remove the bearing snap ring and pull the bearing and drive gear. The drive gear is located over a ball key and care must be observed not to lose the ball. Fig. 4-37.

3. If it is necessary to remove the governor weights this can be done by grinding off the peened end of the weight pin and driving it out with a small punch.

4. If the drive gear was removed press on a new gear, the gear must be pressed over the ball key. Fig. 4-37.

5. Press on a new ball bearing and secure with a snap ring. Fig. 4-36.

6. To assemble the weights to the carrier slide the weight pivot shaft through the weight and place a thrust washer on each side. Fig. 4-38.

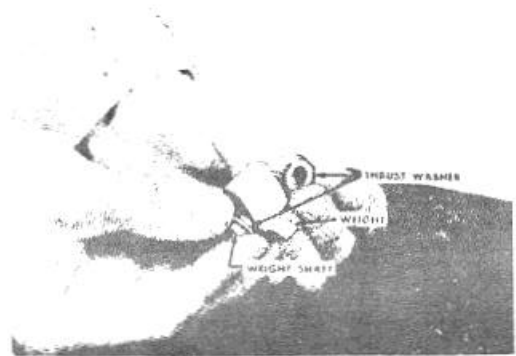

Figure 4-38. Assemble governor weight.

7. Place the weights and shaft inside the weight carrier and insert the pivot pin. Fig. 4-39.

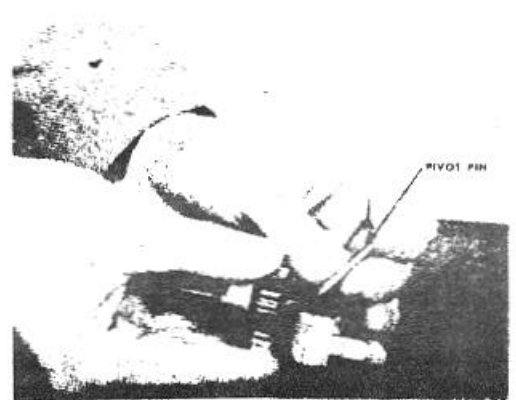

Figure 4-39. Insert the pivot pin.

8. With the pivot pins in place use ST-425 anvil and punch to peen the ends of the pins.

The anvil has two marked positions. Use position No. 1 topeen one end of the pin and use No. 2 for the opposite end. Fig. 4-40. Check after peening to make sure pins are securely fastened.

ASSEMBLY: 1. Press the governor needle bearing into the front cover using ST-421. This is a closed end bearing and must be pressed in with covered side out. Press flush with the housing. Fig. 4-41.

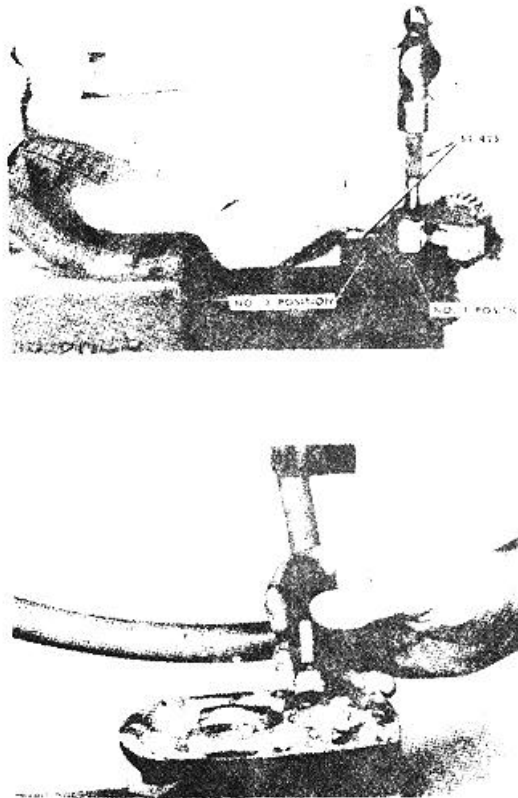

Figure 4-41. Press in governor needle bearing.

2. Heat the cover to 200°F. in boiling water. Press the governor weight assembly and bearing into the front cover. Position is determined by the bearing seating on a shoulder. Fig. 4-42. Check for proper alignment during pressing operation to prevent damage to the needle bearing as the end of the shaft enters the bearing.

3. Replace the governor bearing retainer washer and screw. Fig. 4-43.



Figure 4-42. Press in governor assembly.

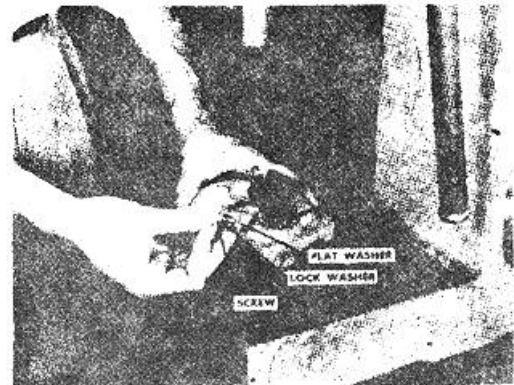

Figure 4-43. Replace bearing lock screw.

4. Press the drive bearing over the drive shaft. Press on the bearing inner race. Fig. 4-44.

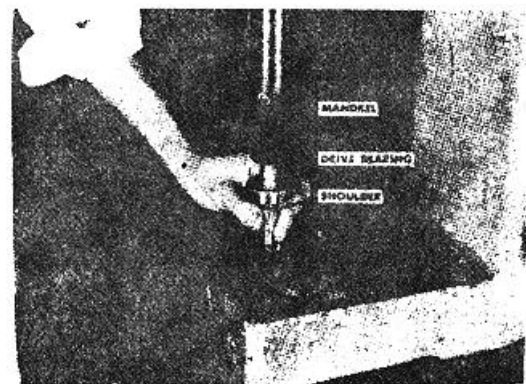

Figure 4-44. Press on drive bearing.

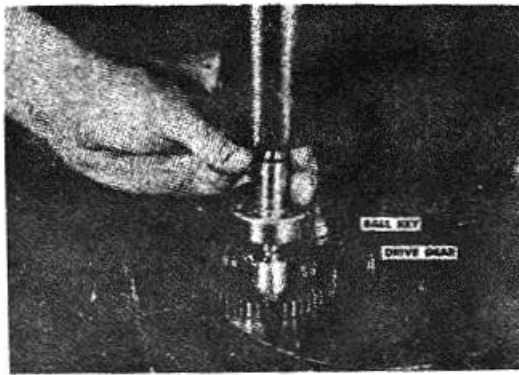

Figure 4-45. Press on governor drive gear.

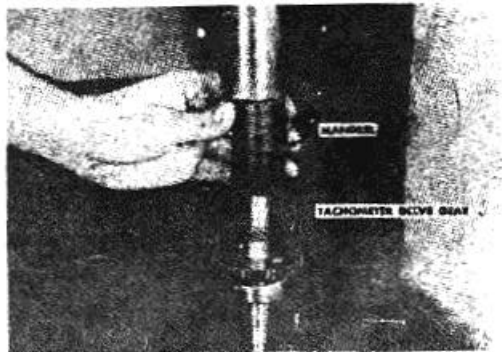

Figure 4-46. Press on tachometer drive gear.

5. Assemble the ball key to the drive shaft with a drop of heavy grease to hold it in place and press the governor drive gear up to the drive shaft bearing. Fig. 4-45.

6. Press the tachometer drive gear in place up to the governor drive gear. Some pumps do not have a tachometer drive. Fig. 4-46. Check to see that all parts are firmly seated on each other.

If the tachometer gear is splined, align drive pin holes in gear and drive shaft before the gear is pressed on. Press pin through gear and drive shaft.

7. Insert the drive bearing snap-ring between the bearing and governor drive gear.

8. Press the main shaft assembly into the front cover. Fig. 4-48.

9. Assemble ST-419 over the main shaft and press in the front cover oil seal. Press the seal in, spring side down, with a quick "SNAP" action.

10. Pressing should be done with the front cover

heated; immediately following the governor assembly while the housing is still hot would be a good time.

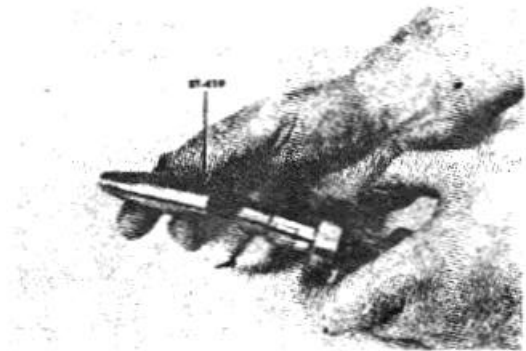

Figure 4-47. Install oil seal tool.

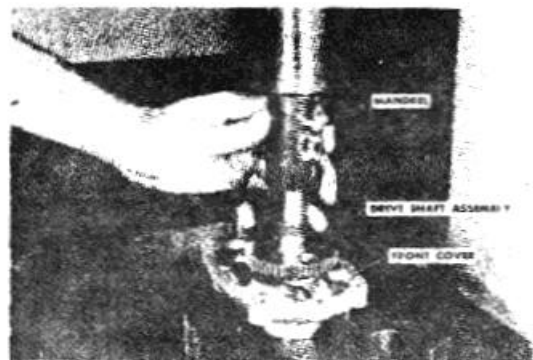

Figure 4-48. Press in drive shaft assembly.

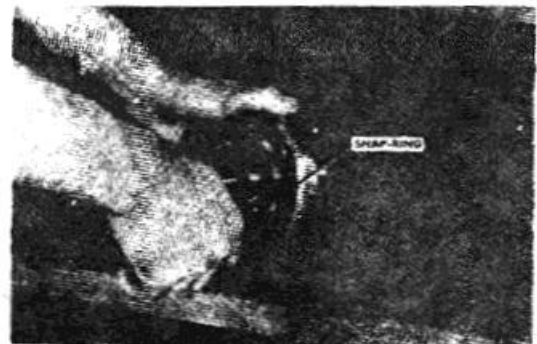

Figure 4-49. Assemble snap-ring in place.

11. Assemble the drive coupling key to the drive shaft and press the coupling into position.

Fig. 4-50. Support the drive shaft assembly on the governor drive gear during the pressing operation.

12. Assemble the retainer cap screw, flat washer and lock-washer to the shaft and tighten in place. Fig. 4-50. Place the coupling in a vise to tighten.



Figure 4-50. Assemble coupling retainer cap screw

Variable-Speed Governor Spring-Pack Housing.

DISASSEMBLY: 1. Screw out the throttle lever setscrew and pull the throttle lever assembly from the spring pack cover. Fig. 4-51.

2. The spring pack cover and bushings are replaceable only as an assembly. Where bushing replacement is required return housing to the factory.

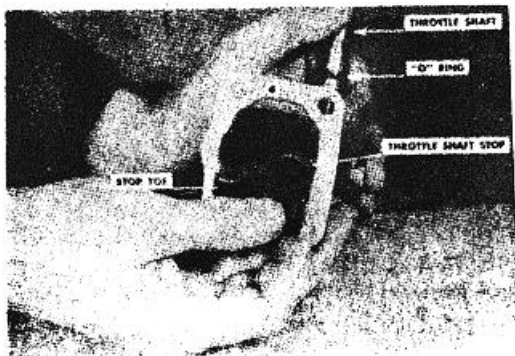

Figure 4-51. Install throttle shaft stop.

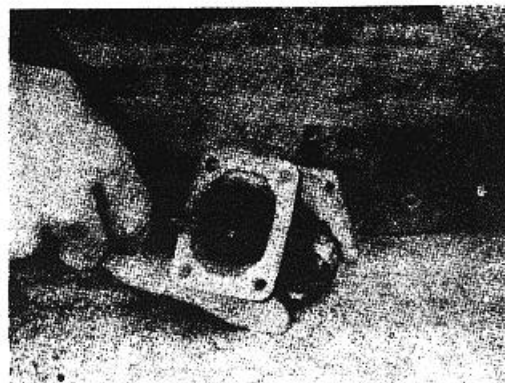

Figure 4-52. Install setscrew.

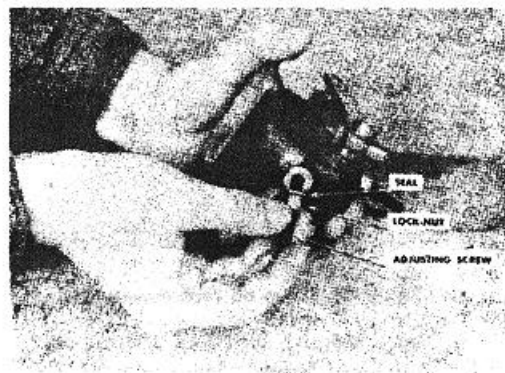

Figure 4-53. Install adjusting screw.

ASSEMBLY: 1. Install new "O" rings on the throttle shaft and lubricate thoroughly.

2. Push the throttle shaft and "O" rings through the bushings and throttle shaft stop. Fig. 4-51. The large toe on the stop goes at the top.

3. Install the throttle shaft setscrew and stake in place. Fig. 4-52.

4. Assemble lever to shaft and install the adjusting screws with a seal between the housing and lock nut. Fig. 4-53.

Fuel Pump Assembly

In all assembly operations be careful to remove burrs, and use a good extreme pressure lubricant on the mating surfaces during all pressing operations. An extreme pressure lubricant aids in pressing and prevents scoring and galling.

Flat steel washers must be used, throughout the pump, next to aluminum to prevent goring by steel spring washers.

The following assembly and adjustment instructions are given with the assumption that worn or defective parts, or sub-assemblies, have been replaced with new or rebuilt parts and assemblies.

Assembly

1. Place the fuel pump housing on the mounting bracket and mount on the holding fixture. Fig. 4-54.

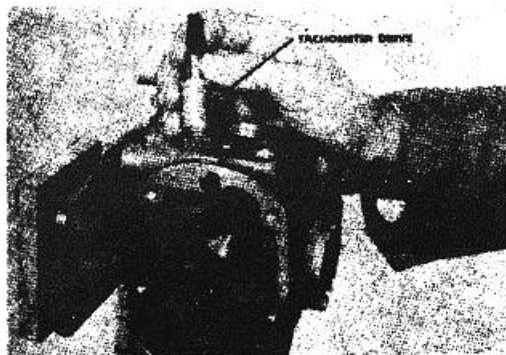

Figure 4-54. Assemble tachometer drive assembly.

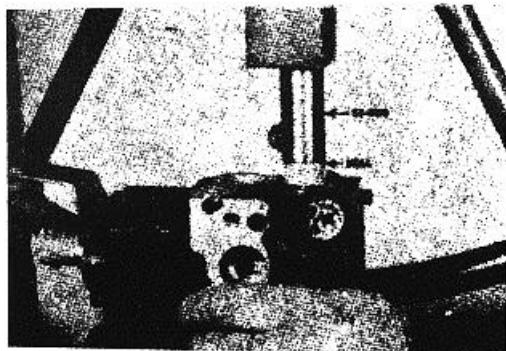

Figure 4-55. Assembling tachometer drive oil seal.

2. Press the tachometer drive assembly into the fuel pump main housing using ST-430 mandrel.

3. Press oil seal on the tachometer drive with sealing lip down. Use ST-420 to assemble seal over split pin. Seal must seat on the drive bushing. Fig. 4-55.

4. Assemble tachometer cover and gasket to the fuel pump housing. Fig. 4-56.

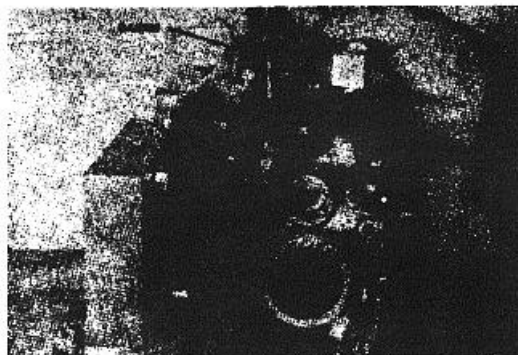

Figure 4-56. Replacing tachometer drive cover.

5. Assemble the filter screen assembly into the housing, the hole in the bottom retainer goes down. Fig. 4-57.

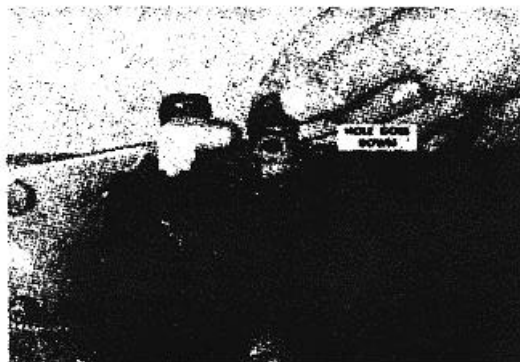

Figure 4-57. Filter screen assembly.

6. Position spring and tighten cover in place. Fig. 4-58. Torque tighten cap to 25/30 ft. lbs. Over tightening is not necessary or desirable. Fig. 4-59.

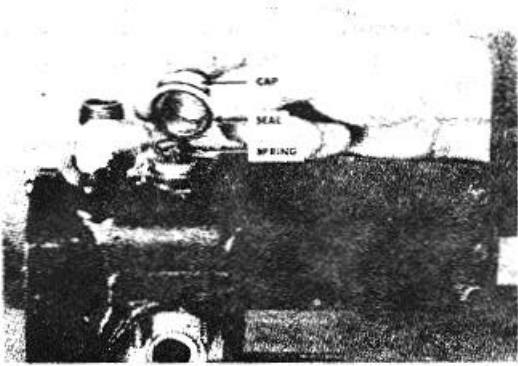

Figure 4-58. Replace filter spring and cap.



Figure 4-59. Tighten filter cap.

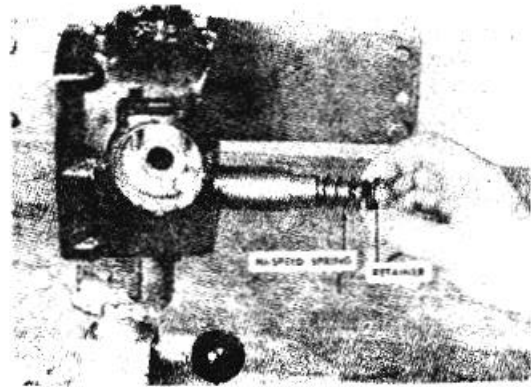

Figure 4-60. Installing standard governor spring pack assembly.

7. **STANDARD GOVERNOR:** a. The governor has one maximum-speed and two idle-speed springs. Maximum speed is changed by replacing the spring or by adding shims. Assemble as shown in Fig. 4-61. Final number of shims will be determined at pump test.

There are several different springs to change maximum speed. These are identified by color stripes as follows:

Speed	Color Stripe
2500	White
2100	Red
2000	Yellow
1800	Green
1500	Brown
1300	Black
1200	Blue
1100	Red & White
1000	Blue & Red
900	Green & White
720	Red & Green

Shims are available in thicknesses of .005, .010 and .020 inch.

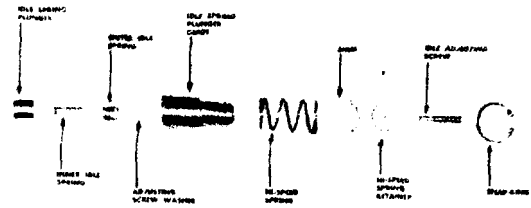

Figure 4-61. Spring pack assembly-standard governor

b. Make sure the outer (large) idle spring seats in the counterbore of the plunger.

c. Slide the governor spring pack assembly into position. This assembly is held in place with a snap ring. Fig. 4-61 and 4-62.

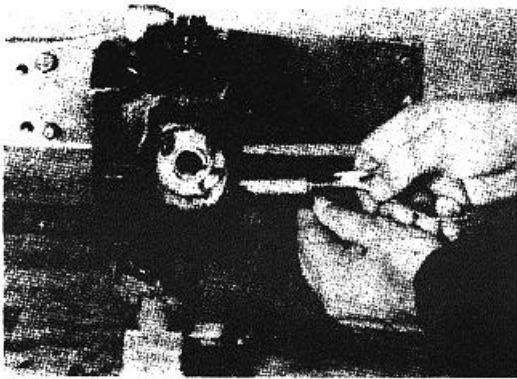

Figure 4-62. Assembling spring pack snap ring.

d. Replace spring pack cover and gasket. Fig. 4-63.

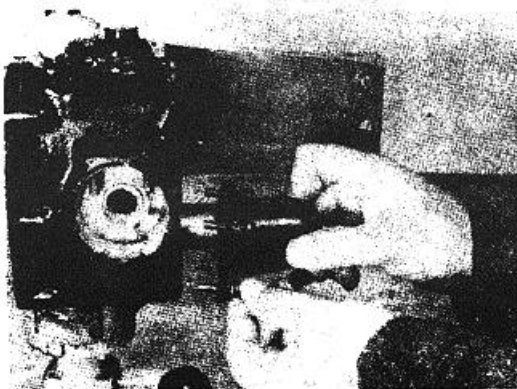

Figure 4-63. Replacing spring pack cover.

8. **VARIABLE SPEED GOVERNOR:** a. Install the governor plunger, idle spring, spring retainer, snap-ring, governor spring and throttle lever plunger in the spring pack housing. Fig. 4-64. Shims may be added under the governor spring during pump testing.

b. Place a new gasket on the spring pack cover and assemble cover to fuel pump. Fig. 4-65.

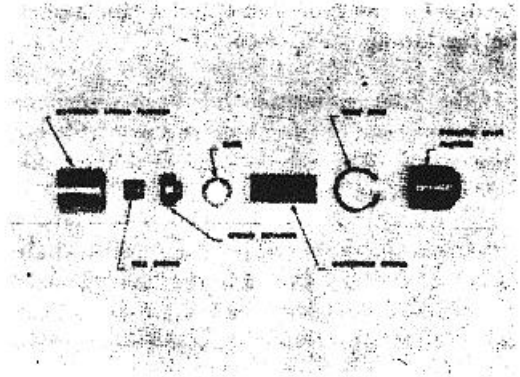

Figure 4-64. Variable speed governor spring assembly.

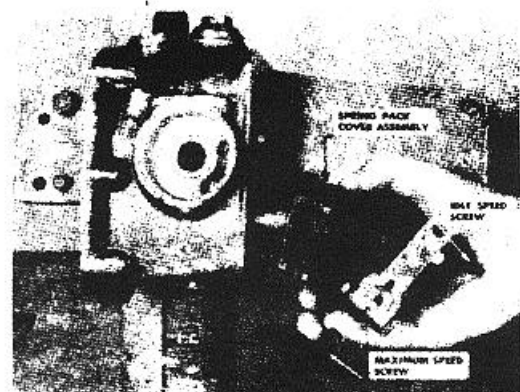

Figure 4-65. Install cover assembly.

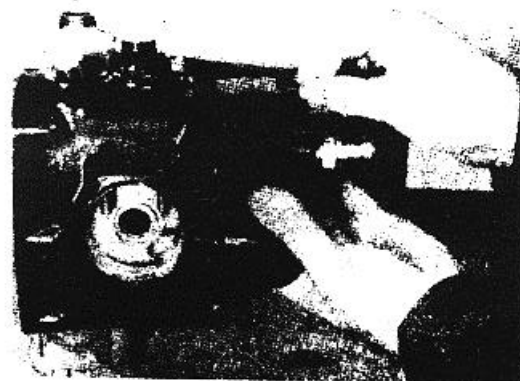

Figure 4-66. Assembling gear pump to fuel pump.

9. Assemble the gear pump and a new gasket to the fuel pump. Fig. 4-66.

10. If the inlet connection has been removed, install in position, or plug hole and assemble on the test stand. Use Crane Lead Sealer on the threads to prevent leaks.

11. Replace the "O" ring on the throttle shaft using ST-422. Fig. 4-67. Insert the throttle shaft assembly. Fig. 4-68 and Fig. 4-69. Coat assembly with Lubriplate before inserting. The "O" ring must be replaced each time the throttle shaft is removed regardless of appearance.

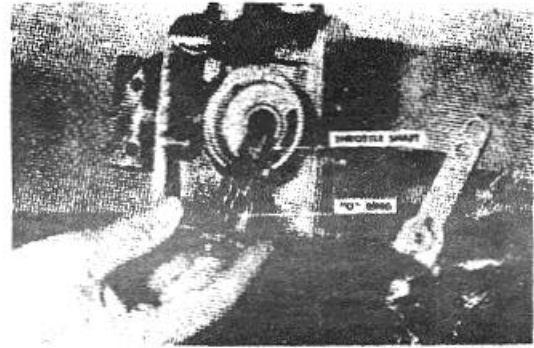

Figure 4-69. Throttle shaft assembly variable speed governed pump.

12. The throttle lever can be assembled in any position as required by the application.

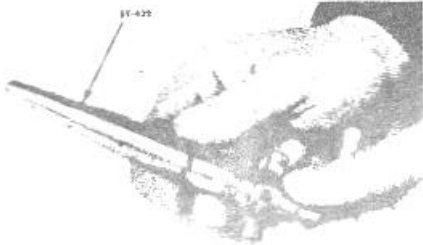

Figure 4-67. Installing throttle shaft "O" ring.

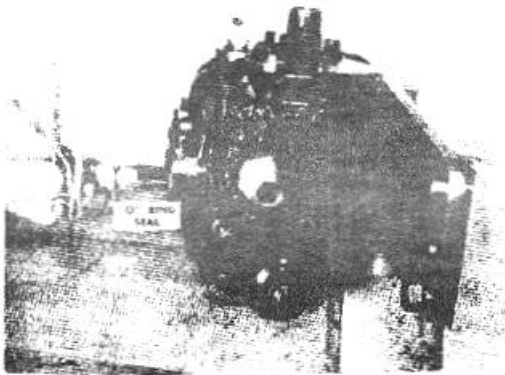

Figure 4-68. Assembling throttle shaft to pump housing-standard pump.



Figure 4-70. Replace governor plunger.

13. Place the governor plunger in the governor plunger barrel. Fig. 4-70.

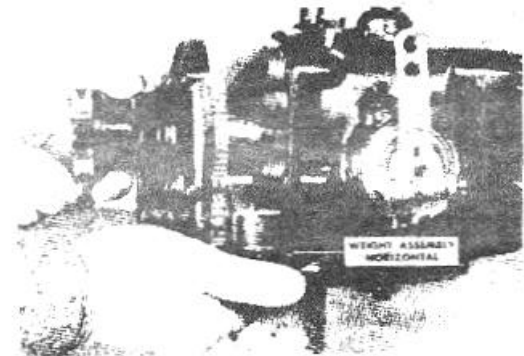

Figure 4-71. Placing front cover in position.

14. Place a new gasket over the front housing cover dowel pins.

15. Place front cover assembly in position. The governor weight assembly must be in a horizontal position with the weights held in; the governor plunger driver also must be horizontal. The drive shaft should be rotated slowly as the tachometer gears come in to mesh. Fig. 4-71.

16. Assemble the capscrews and tighten front cover in position. Always use flat washers next to aluminum. Fig. 4-72.

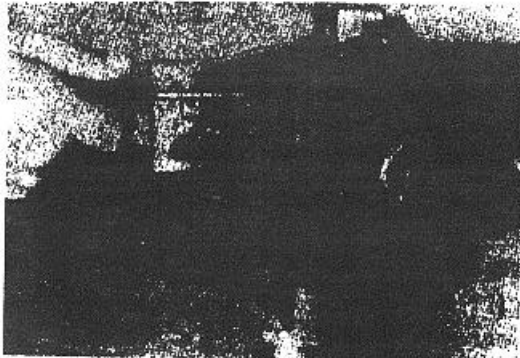

Figure 4-72 Tightening front cover

17. If the pressure regulator has been disassembled, assemble in order shown in Fig. 4-73. The number of shims should be the same as removed until the fuel pump is tested at which time they may have to be increased or decreased.

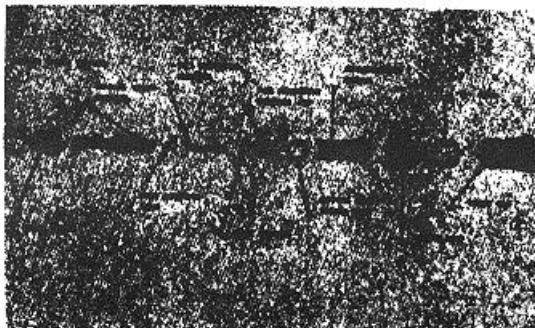

Figure 4-73. Pressure regulator assembly

18. Assemble the pressure regulator in the fuel pump. Tighten with 20/25 ft. lb. torque. Figure 4-75.

CAUTION: DO NOT OVERTIGHTEN THE PRESSURE REGULATOR.

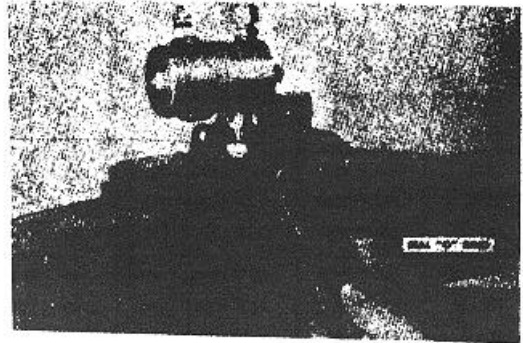

Figure 4-74. Replacing pressure regulator

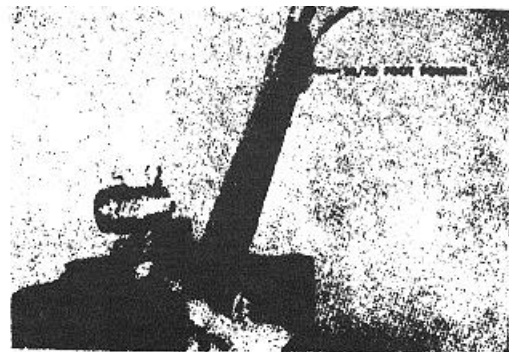

Figure 4-75. Tighten pressure regulator

19. Mount the shut-off valve assembly with a new "O" ring. Fig. 4-76.

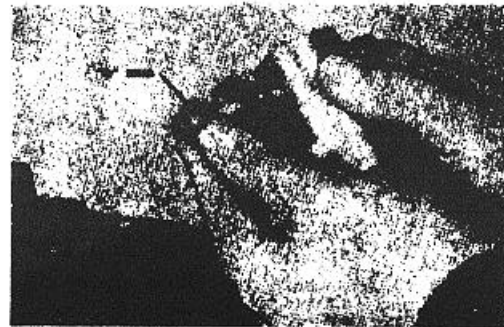

Figure 4-76. Installing "O" ring gasket on shut-off valve

**TABLE: PT FUEL PUMP CALIBRATION PRESSURES
(Rated Horsepower and Speed)**

ENGINE MODEL	RATED HP AT SPEED	TEST STAND CALIBRATION PRESSURES				THROTTLE LEAKAGE CC/MIN	BY-PASS VALVE SETTING WITH ST-492	BY-PASS VALVE PLUNGER	MAXIMUM MANIFOLD PRESSURE ON ENGINE	USE INJECTOR BODY NO.	MAXIMUM FUEL RATE LB./HR.
		MANIFOLD AT SPEED	IDLE 3000 RPM	GOVERNED SPEED PSI RPM							
A-6	100 @ 2200	37 @ 2100	4	30	2250	300	.024	106244 T	47/52	101835	50
J-6	95 @ 1800	33 @ 1700	4	40	1880	300	.027 Less .060	105190 Q	40/45	101835	43
JF-6	105 @ 2200	40 @ 2100	4	40	2300	300	.024	106244 T	51/56	101835	49
JN-6	125 @ 2500	66 @ 2400	6	40	2620	300	.024	106244 T	68/73	101835	55
JNS-6	165 @ 2500	116 @ 2400	18	40	2620	300	.011	102676 N	147/152	101835	76
JS-6	150 @ 2500	113 @ 2400	25	40	2620	300	.036	101523 D	140/145	101835	76
JT-6	165 @ 2500	113 @ 2400	23	40	2620	150	.026	101543 E	135/140	101835	70
JT-6	175 @ 2500	120 @ 2400	10	40	2610	150	.007	111389 AB	148/153	101835	74
H-4	100 @ 1800	58 @ 1700	15	40	1900	300	.036	103363 P	96/101	102082	46
HRC-4	110 @ 1800	61 @ 1700	15	40	1900	300	.036	103363 P	98/102	102082	50
NHC-4	120 @ 1800	64 @ 1700	10	40	1870	300	.011	103363 P	116/121	102082	51
H-6	150 @ 1800	67 @ 1700	20	40	1870	300	.015	101825 F	91/96	102082	68
HR-6	165 @ 1800	75 @ 1700	40	40	1870	300	.015 Less .015	101543 E	103/108	102082	73
HRFB-6	180 @ 2000	86 @ 1900	45	40	2090	300	.015 Less .015	101543 E	114/119	102082	81
HRS-6	225 @ 1800	92 @ 1700	20	40	1890	300	.036	100527 B	114/119	102083	108
HS-6	200 @ 1800	87 @ 1700	20	40	1890	300	.049	112124 AC	103/108	102083	94
NH-6	200 @ 2100	103 @ 2000	20	40	2220	300	.013	102101 G	140/145	102082	88
NHRS-6	300 @ 2100	135 @ 2000	20	40	2220	300	.026	102160 M	168/173	102083	140
NHS-6	275 @ 2100	105 @ 2000	25	40	2220	300	.026	100527 B	140/145	102083	128
NRT-6	300 @ 2100	118 @ 2000	25	40	2220	75	.015	102160 M	144/149	102083	127
NRT-6	335 @ 2100	146 @ 2000	22	40	2220	75	.015 Less .013	106450 U	173/178	102083	142
NT-6	235 @ 2100	126 @ 2000	16	40	2220	75	.026	102160 M	171/176	102082	95
NT-6	250 @ 2100	168 @ 2000	6	40	2220	75	.015 Less .015	106062 S	211/216	106948	104
NTO-6	262 @ 2100	175 @ 2000	2	40	2220	300	.018	112765 AG	223/228	106948	110
NVH-12	400 @ 2100	123 @ 1600	30	70	2260	300	.036	102676 N	128/133	102082	168
NVHS-12	550 @ 2100	156 @ 1600	34	70	2260	300	.021	106062 S	177/182	102083	256
L-6	250 @ 1000	101 @ 1800	14	70	2060	300	.076	102676 N	143/148	102270	102
LR-6	300 @ 1100	133 @ 2000	14	70	2290	300	.049	102160 M	173/178	102270	134
VT-12	600 @ 2100	146 @ 1600	35	70	2260	300	.036	101257 C	155/161	102083	248

NOTES:

1. Pressures on the engine will be reached at the point where the governor cuts in and not at rated governed speed. Check with ST-435.
2. Use only 6-cylinder manifold orifice to set maximum fuel manifold pressures on test stand.
3. By-pass valve settings made with ST-492 which call for indicator readings of .015" Less .015", etc., must be made by obtaining a .015" indicator reading and then removing .015" shim from under the by-pass valve spring.
4. A code letter is electro-etched on each by-pass valve plunger corresponding to part numbers as shown in the table.

Testing and Calibrating the PT Fuel Pump

THE TEST STAND: Cummins ST-445 test stand is especially made to test the PT fuel pump, or ST-444 conversion kit is available to adapt the Cummins ST-273 fuel pump test stand (for other Cummins fuel pumps) to test the PT fuel pump.

TEST OIL .SPECIFICATIONS: Viscosity must be 37 Saybolt Universal at 100°F.; equivalent to No. 2 Diesel fuel oil.

ORIFICE SPECIFICATIONS: There are two orifices on the ST-445 test stand, a manifold orifice and an idle orifice and they should be checked at regular intervals to make sure fuel flow is within these limits:

- a. **Manifold Orifice:** Must allow a flow of 579/581 lbs./hr. test oil at 90 psi constant pressure at 95°F. On ST-444 conversion kit obtained before 1955 this is the 6 cylinder orifice.
- b. **Idle Orifice:** Must allow a flow of 56.5/57.5 lbs./hr. test oil at 90 psi constant pressure at 95°F.

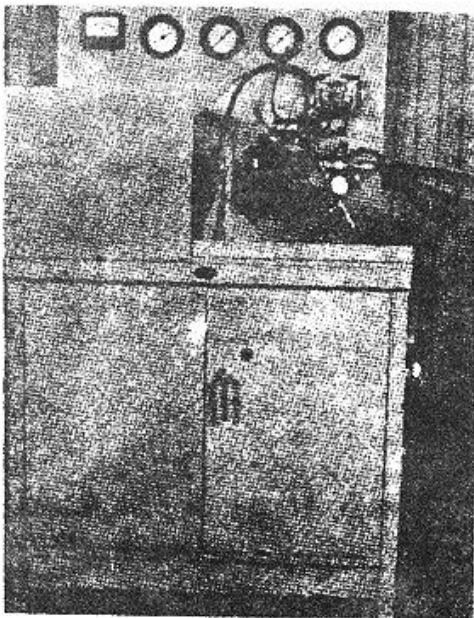

Figure 4-77. PT fuel pump test stand-ST-445

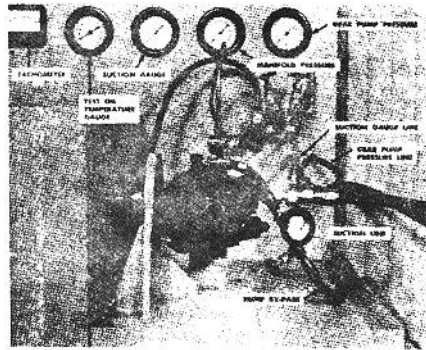

Figure 4-78. Pump and lines on test stand

PUMP HOOK-UP: 1. Install the proper drive coupling to the test stand drive shaft.

2. Mount the pump on the mounting bracket (flange-type pump to ring or rear mount pump to back bracket) and adjust test stand drive coupling, where rubber buffer drive is used, so there is 1/16 inch space between coupling halves.

3. Squirt a few drops of clean lubricating oil in the gear pump inlet hole, then connect suction line.

4. Connect the gear pump pressure line to the gear pump.

5. Connect the gear pump suction line to the inlet fitting adapter.

6. Install the fuel pump drain hose, gauge and valve to the pump drain fitting.

7. Connect the copper line from the orifice block to the fuel pump shutoff valve.

RUN-IN: 1. Open pump shut-off valve and manifold orifice valve. Open throttle, start and run pump at 500 rpm until manifold pressure gauge shows pressure. If pump does not pick up check for closed valves in the suction line or for an air leak.

2. If pump is newly rebuilt or has been opened, run at 1500 rpm for five minutes to flush pump and allow bearings to seat.

3. Before starting calibration, check the pump fuel flow in the graduate and the orifice block sight gauge for air. If air is present, correct leak before continuing test. Check for leaks " described in the paragraph "Check For Air Lax", following.

4. Continue to run pump at 1500 rpm and turn rear throttle stop screw in or out to find maximum manifold pressure at full throttle.

- A. With a standard governed pump the throttle screws will be readjusted later.
- B. If the pump has a variable speed governor the throttle shaft is locked in full throttle position, do not readjust.
- C. On a dual or torque converter governor pump, the throttle must be locked in shutoff position and the converter driven governor idle adjusting screw "C" (Fig. 4-83) turned "in" until the spring is compressed. The converter driven governor must be set on the engine.

SIT APPROXIMATE GOVERNED SPEED: 1. Open valve to the manifold orifice and close all other orifice valves.

2. Move throttle control lever to full-fuel position.

3. Increase pump speed until manifold pressure begins to drop; this should be approximately pump governed speed.

4. If speed is low, add shims between the high speed governor spring and spring retainer. To reduce speed remove shims. See Fig. 4-61. On variable speed and torque converter pumps adjust maximum-speed screws (engine governor on torque converter pump) before you add or remove any shims.

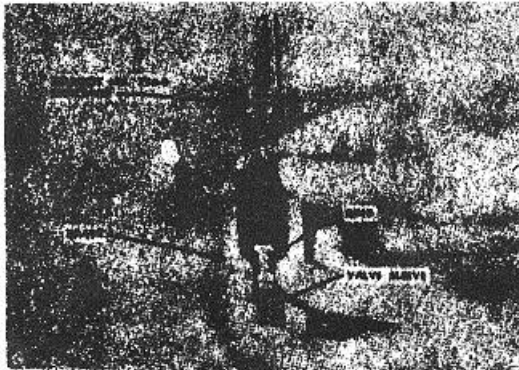

Figure 4-79. See spring load

SET PRESSURE-REGULATOR SPRING LOAD: 1.

Place the complete pressure regulator assembly in ST-492. See Fig. 4-79. Use Starrett No.196-B indicator or equivalent.

2. Hold the assembly in place by holding the by-pass valve sleeve and ring against the fixture so the cap will be free to move up and down.

3. Compress the by-pass valve spring by pressing down on the by-pass valve cap. With spring compressed set indicator on "0".

4. Release cap and check indicator reading; it should indicate the amount of travel listed in the table on Page 4-20 or 4-24 under "By-Pass" Valve Settings With ST-492" if not add or remove shims from under the by-pass valve spring. See Fig. 4-73. Several readings should be taken to make sure the spring is moving freely; choose average value of several readings. Readings within .002" are within the required accuracy range. Make sure the shims you use are flat.

5. By-pass valve settings made with ST.492 which call for indicator readings of ".015 less .015", etc., must be made by obtaining a .015" indicator reading and then removing .015" shim from under the by-pass valve spring.

6. Shims are available as:

Part No. 101841 --.005" thick

Part No. 101842 --.010" thick

Part No. 101843 --.020" thick

SET MANIFOLD PRESSURE: 1. Open valve to manifold orifice and close other orifice valves.

2. Place throttle in full fuel position and increase pump speed to 100 rpm less than rated governed speed. For example, a speed of 2000 rpm on a 2100 rpm pump.

3. Turn rear throttle stop screw "in" until fuel pressure is reduced 3 psi. Lock screw. Disregard this step on variable speed and torque converter pumps.

4. Adjust the valve in the pump suction line to give 8 inches vacuum. Fuel temperature must be 90° to 100°F. during this setting

5. Set the manifold pressure to value listed in table on Page 4-20 or 4-24 under "Manifold At Speed" by adding or removing shims from under the fuel adjusting plunger.

6. Remove shims to raise pressure or add shims to lower pressure. See Fig. 4-73.

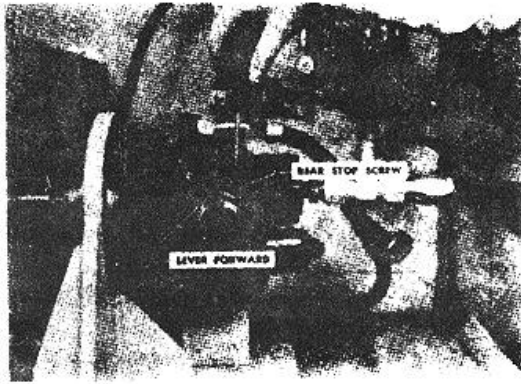

Figure 4-80. Set rear stop screw

7. Shims are available as:
 Part No. 70750 - .010" thick
 Part No. 70750-A - .005" thick
 Part No. 70750-B - .002" thick

8. Install the pressure regulator assembly and tighten cap to 20/25 foot-pounds and recheck pressure setting.

SET FORWARD THROTTLE STOP SCREW: 1. Close all manifold orifice valves and open valve at end of orifice block.

2. Run hose from valve at end of orifice block into a 500 cc glass graduate.

3. Move throttle to idle position and raise pump speed to 100 rpm below rated governed speed.

4. Screw the forward throttle stop screw "in" until the pump delivers amount of fuel indicated under "Throttle Leakage" in table on Page 4-20 or 4-24. Lock screw at this setting.

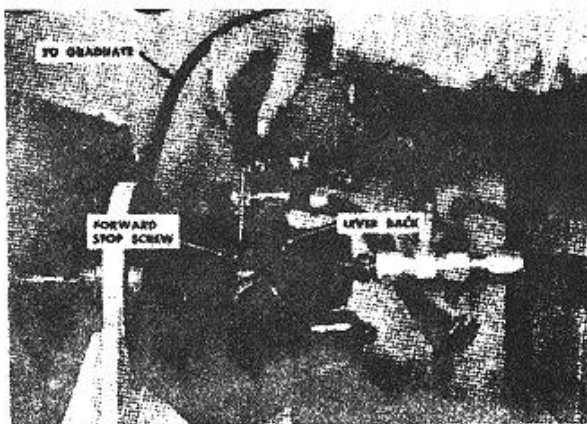

Figure 4-81. Set forward stop screw

Note: This setting not required on variable speed or torque converter pumps throttle stops are set as outlined under "Run-In" previously described.

SET GOVERNED SPEED: 1. Close valve to glass graduate and open valve to manifold orifice, then move throttle to full-fuel position.

2. Raise pump speed until maximum manifold pressure is reached. Continue to increase pump speed until the manifold pressure drops to 70 psi if pump is for L, LR, NVH(S) or VT-12 engines or to 40 psi for all other engines. Hold this pressure and check speed; it should be a listed under "Governed Speed - PSI - RPM" in table on Page 4-20 or 4-24. If speed is low add shims between high-speed governor spring and spring retainer; remove shims if speed is too high.

3. Each .001 inch shim thickness changes speed approximately 4 rpm. See Fig. 4-61.

4. Each time the governor spring pack is removed the pump must be run until free of air; otherwise, the indicated speed will not be accurate due to air in the pump body around the governor weights.

SET IDLE SPEED: 1. Open valve to idle orifice and close other orifice valves.

2. Set throttle in idle position and run pump at 500 rpm.

3. With the spring pack cover removed, manifold pressure should be as listed under "Idle Speed" in table on Page 4-20 or 4-24. If pressure is low, screw idle adjusting screw "in"; to lower pressure, back screw "out".

WARNING: Always set idle speed after the throttle screws are adjusted.

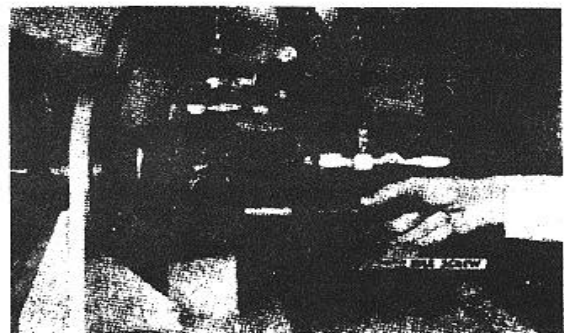

Figure 4-82. Set idle speed

CHECK FOR AIR LEAKS: 1. If at any time during the calibration of the pump air is drawn with the fuel into the system, the calibration will be in error. When this occurs, the quickest means of finding the trouble is to pressurize the entire pump and system with a hand priming pump at the suction gauge tap.

2. Close the shut-down valve and the gate valve in the pump body drain line. Close suction to pump.

3. Hold fuel tander pressure of 30 psi for 1 minute or longer.

4. Dry the pump thoroughly so that leaks can be detected.

PREPARE PUMP FOR TEMPORARY STORAGE:

1. Remove the pump from the stand making sure that the suction fitting is not moved or disturbed.

2. Loosen spring pack cover and drain pump through pipe plug at bottom of body.

3. Cover all openings with tape and blind fittings until the pump has been installed and the engine lines are ready to be connected.

**TABLE: PT FUEL PUMP CALIBRATION PRESSURES
(Special Horsepower Ratings)**

ENGINE MODEL	RATED HP AT SPEED	TEST STAND CALIBRATION PRESSURES				THROTTLE LEAKAGE CC/MIN	BY-PASS VALVE SETTING WITH ST-492	BY-PASS VALVE PLUNGER	MAXIMUM MANIFOLD PRESSURE ON ENGINE	USE INJECTOR BODY NO.	MAXIMUM FUEL RATE LB./HR.
		MANIFOLD AT SPEED	IDLE 300 RPM	GOVERNED SPEED PSI RPM							
H-6	132 @ 1600	57 @ 1500	20	40	1630	300	.068	101825 F	59/64	102082	
H-6	143 @ 1800	61 @ 1700	20	40	1880	300	.015	101825 F	90/95	102082	
NH-6	165 @ 2000	70 @ 1900	10	40	2090	300	.015 Less .020	102773 Y	92/97	106948	
**NHS-6	235 @ 2100	82 @ 2000	25	40	2220	300	.044	103363 P	107/112	102083	
NHRS-6	255 @ 2100	118 @ 2000	20	40	2220	300	.026	102160 M	127/132	102083	
VT-12	585 @ 2100	160 @ 1600	14 75	70	2200	300	.036	101257 C	149/154	102083	230
NH-6	95 @ 1370					300	.024	106244 T	33/38	106948	
NHRS-6	195 @ 1800					300	.036	103363 P	95/100	109747	
NRT-6	260 @ 2100			40	2220	75	.092	103363 P	118/123	109747	
NVH-12	366 @ 1950					300	.053	102676 N	122/127	106948	
VT-12	330 @ 1470	1600		70	2200	300	.011	101275 X	59/64	109747	
VT-12	400 @ 2100	1600		70	2200	300	.015 Less .020	105096 T	92/97	109747	
VT-12	450 @ 2100	1600		70	2200	300	.015 Less .020	101543 E	101/106	109747	
VT-12	500 @ 2100	1600		70	2200	300	.032	102101 G	123/128	109747	
VT-12	550 @ 2100	1600		70	2200	300	.036	106450 U	141/146	109747	
VT-12	420 @ 1800	1300				300	.015 Less .020	105190 Q	97/112	109747	

**BM-35442 fuel pump.

NOTES

4-25

NOTES

4-26

SECTION V

Maintenance and Testing of Injectors

Clean PT injector cup spray holes in the same manner as other Cummins injectors and as described in the 11 and NH Shop Manual Bulletin No. 6301-C. Cleaning of the injectors and replacement of the "O" ring on the cup end of the injector body are described below.

CLEANING INJECTORS: 1. In the PT system fuel metering is a dual function of the pump which regulates fuel pressure and the injectors which permit the metering orifice to be uncovered for an accurately controlled period of time. Any change in the *pressure*, *orifice* or *time*, will affect the amount of fuel delivered to the combustion chamber.

2. There are two things which will interfere with the normal functions of injector orifices:

- a. Dirt or carbon accumulation in the orifices or passages to or from orifices.
- b. Changing size or shape of orifices, particularly by wrong cleaning methods.

3. Always soak dirty injectors in a good carbon solvent such as Bendix Metal Clean to remove carbon. After soaking dip in a neutral rinse such as mineral spirits and blow clean with compressed air.

4. *Never use cleaning wires in orifices.*

5. In a few cases engines have lost as much as 40% of their rated horsepower because of dirty or carboned orifices, and the lost horsepower was regained after proper cleaning.

NOTE: Practically all cases of carboned orifices are due to incorrect injector adjustment. For adjustment see Page 3-2.

6. A good strong magnifying glass can be used to check for burrs and distorted radii in orifices. When injector orifices are damaged by wrong cleaning methods the injector cannot be made to function properly.

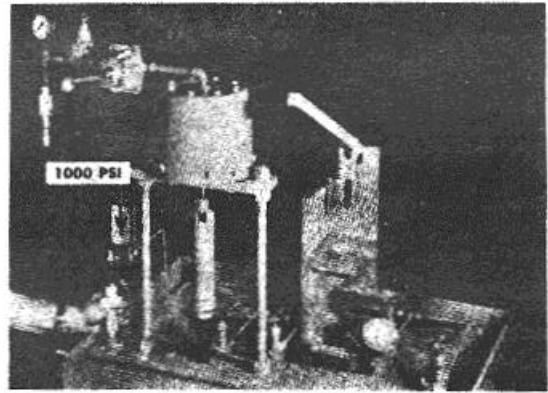

Figure 5-1. Checking injector for leakage a plunger

CHECK INJECTOR FOR WORN PLUNGER OR BODY:

Worn injectors may cause dilution from excessive plunger to body clearance; it may occur as a result of a cracked injector body or cup, or from damaged "O" rings. Check injectors as follows:

1. Assemble injector.
2. Plug off injector inlet and drain connection holes.
3. Mount injector in ST-272 injector test stand, Fig. 5-1, with the cup in the bronze seat and with plunger lifted 045 inch off its seat. Use same manner as for disc type injectors on ST-272.
4. Test at maximum of 1000 psi with fuel flowing upward through the cup spray holes.
5. If the counterbore at the top of the injector body fills with fuel in less than 15 seconds, the plunger clearance is excessive and might cause dilution in the engine.
6. During this check inspect injector for leaks around the cup, body and plugs.
7. If injectors do not pass the test correction must be made by installing new parts, checking assembly or return of injector to the factory for refitting of plungers.

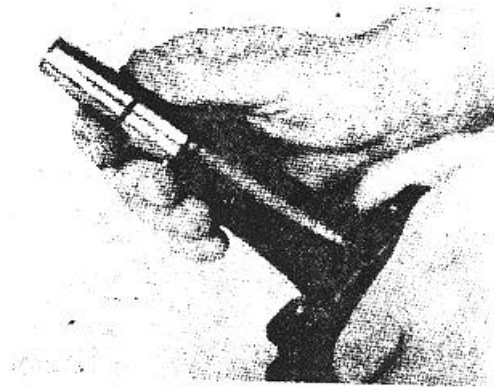

Figure 5-2. Installing "O" ring

LUBRICATION OF INJECTOR PLUNGERS: 1. Initial lubrication of injector plungers is important on the PT injector.

2. At any time you remove an injector plunger, lubricate it with a thin coat of Molycote Type M-55 (ready mixed), or a mixture of lubricating oil and Molycote Type Z.

RELIEVE CUP END OF J, H, NH AND NVH INJECTORS: 1. If the cup end of J, H, NH and NVH series injectors are not relieved as shown in Fig. 5-3 the relief should be added. Addition of the relief will improve cup gasket to body contact and give an improved seal.

2. Use ST-102 with ST-102-5 cutter to relieve the end of J series injectors. The center of the cutter acts as a stop to prevent cutting too deep. The relief should be .005 to .010 inch deep.

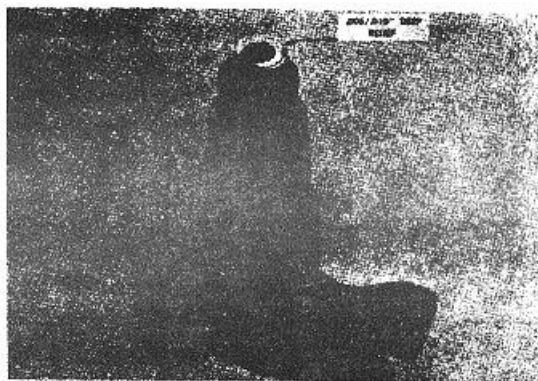

Figure 5-3. Relief on injector body

3. Use ST-131 with ST-131-5 cutter to relieve the end of H, NH and NVH series injectors.

4. When you install injector cups on J, H, NH and NVH series injectors with the relief, tighten cups to 60 foot-pounds with a torque wrench.

INJECTOR "O" RING REPLACEMENT: 1. The injector cup "O" ring should be replaced new each time the cup is removed. Fig. 5-2.

2. Install an "O" ring assembly tool over the threaded end of the injector body. These tools are available as:

- ST-426 for J series injectors
- ST-427 for N, NH, VT and NVH series injectors
- ST-477 for L and LR injectors

3. Dip the "O" ring in clean lubricating oil and slide it over the assembly tool into the groove on the injector body.

INSTALLING INJECTOR CUPS: 1. Over tightening injector cups will distort the cup and prevent injector plunger from setting properly. Under tightening may cause engine to miss.

2. Tighten injector cups on injector bodies with a torque wrench. (An adapter wrench is available for use with a socket and torque wrench, see table below). Tightening values are as follows:

<i>Wrench Adapter</i>	<i>Injector Cup</i>	<i>Tighten To</i>
ST-500	L and LR	300 ft. lbs.
ST-499	J, JS, JT	70 ft. lbs.
ST-498	All Others	75 ft. lbs.

3. If the injector plunger does not seat properly in the cup, change the cup rather than try to lap the plunger and cup together. Lapping will change the relationship between the plunger groove and metering orifice, and disturb fuel metering.

4. Always use a new injector cup gasket when you assemble the cup to the body to avoid distortion of the cup. When the cup is tightened to the body the gasket compresses everywhere except under the milled slots on the end of the body; then if reused, the uncompressed areas may cause the cup to cock and prevent the plunger from seating properly.

SECTION VI

Trouble Shooting the Fuel System

When checking an engine with a PT fuel system, the first step should always be to determine if trouble exists in the fuel system, or in other parts of the engine or vehicle. After the fuel system has been proven to be the source of trouble, the following program is outlined to serve as a guide in correcting the fault in the pump, the piping or the injectors.

A: Complaint: ENGINE WILL NOT START

Cause	Correction
1. Tanks out of fuel.	1. Fill all tanks connected to engine.
2. Suction leaks between tanks and pump.	2. Check all fittings for tightness as well as fuel filter can and gasket. Replace fittings as required. If fitting dope is required use Crane Lead Sealer #2.
3. Suction air leak at top expansion plug on gear pump.	3. Repair can sometimes be made by peening the edge of the plug with a flat end punch. If not stopped by peening, replace the gear pump.
4. Suction air leak at pressure regulator cap.	4. Replace "O" ring seal on cap if mutilated. Replace the pump housing if the seal surface is damaged. Tighten the cap to 20/25 ft. lbs. torque.
5. Pressure regulator plunger stuck open or spring left out.	5. Make correct assembly of the parts. If the plunger is tight, it should be lapped into the sleeve with fine lapping powder until the high spots are removed.
6. Closed shut-down valve on pump.	6. This occurs frequently; always check for opening of valve.
7. Suction lines and gear pump dry on initial installation.	7. Fill gear pump with clean lube oil to prime and prime suction lines. The fuel filter should be filled with fuel to start new system.
8. Broken drive shaft.	8. Remove 1/8 NPT plug from gear pump and bar engine over to see if gears are turning. Replace damaged parts if required.

B: Complaint: REPEATED HARD STARTING

Cause	Correction
1. Scored gear pump or worn gears.	1. Make suction lift test on calibration stand and replace gear pump if pump does not lift properly.

2. Sticking pressure regulator plunger or loose cap.
3. Suction line leakage or leaking fuel filter.
4. Cracked fuel tank bulkhead fitting.

2. Make proper assembly of pressure regulator and tighten cap to 20 ft. lbs. Lap plunger with fine powder to remove high spots until free in sleeve.
3. Pressure suction line with priming pump to 100 psi. Correct leaks using new tubes, fittings or filter gasket. Use Crane Lead Sealer #2 on pipe threads.
4. Repair fitting by welding or with new parts as required.

C: Complaint: LUBE OIL DILUTION

Cause	Correction
1. Loose injector inlet or drain connections.	1. Tighten to 20/25 ft. lbs. with torque wrench.
2. Cracked or worn connection gaskets.	2. Inspect and replace defective gaskets on the connection each time the connection is assembled to the injector.
3. Cross threaded injector connection. (or) injector.	3. Inspect and replace damaged connection and Always start the connections before fore torquing the injector hold-down nuts to prevent cross-threading.
4. Worn injector cup spray holes.	4. Replace worn cups with new cups.
5. Wrong injector cups.	5. The correct cup must be used on' each model engine since the spray holes are different in size. The wrong size cup may over-penetrate and wet the cylinder liners with fuel oil.
6. Mutilated "O" ring-injector cup seal.	6. Replace "O" ring with new parts. Inspect for cause of mutilation if ring is cut; all burrs must be removed before assembly.
7. Cracked injector body or leaking body plugs.	7. Pressure test the body at 500 psi to determine leaks. Replace defective injector with new part.
8. Excessive injector plunger clearance due to wear.	8. Make plunger leakage test as specified in injector testing and replace worn injector as required.

D. Complaint: ENGINE FLOATING OR POOR DECELERATION

Cause	Correction
1. Throttle linkage sticking or binding. movement of linkage.	1. Inspect linkage and provide clearance for
2. Throttle spring incorrectly positioned, such that the pump throttle has backlash at idle position.	2. To prevent excessive throttle backlash, the spring must be attached at the pump throttle lever and not on any part of the linkage.

3. Idle springs out of position or idle plunger in spring pack stuck.

4. Throttle leakage set too high.

5. Restriction in drain manifold or drain line.

6. Plugged drain orifice

E. Complaints: FUEL LEAKS

Cause

1. Leak at a gasket surface.

2. Leak at pump seals.

F. Complaints: IDLE SPEED TOO LOW OR TOO HIGH

Cause

1. Idle speed too low.

2. Idle speed too high.

3. Make inspection of spring pack parts and assemble springs in correct position. Lap idle plunger to prevent binding. The fit must be free.

4. Set to 270-330 cc/min. on test stand as specified. On installation where setting is required without calibration stand, the throttle should be advanced until the deceleration time of the engine is increased 1 second above the minimum time obtained with adjusting screw completely out. Back the setting screw 1/8 turn and lock in position. The setting must be done on a hot engine.

5. Check the drain line for rubber flaps, ice, etc. Remove the restriction; replace the line if necessary. Replace the drain manifold if damaged. Check the size of drain line. It must be No. 8 Stratoflex or equivalent hose.

6. Check for deformed cup gasket and clean orifice.

Correction

1. Dope gasket with Crane Lead Sealer #2 if - required. Use only a very thin coat on the gear pump. Thin the Sealer with oil if necessary to obtain a thin coat. Replace warped or marred bodies.

2. Replace the leaking seals and replace mating shaft if worn or cut. Pack the seal with lubricant before assembly. Lubriplate should be used on the throttle shaft "O" ring. Pack the tachometer seal cavity with clean grease before connecting the tachometer cable.

Correction

1. Check idle with hot engine; not cold engine. Check to insure that transmission is not binding or that torque converter is cold. Check to insure that idle springs are assembled correctly. Increase the speed by turning the idle adjusting screw inward with the engine running.

2. Check for drain line being restricted or the throttle linkage may be holding the throttle open. If engine roll heavily the large diameter idle spring is assembled incorrectly; out

of its seat. Decrease the idle speed by backing the idle adjusting screw out. This may be done with engine running.

G. Complaint: FUEL TANKS OVERFLOWING

Cause	Correction
1. Single tank overflowing.	1. The tank vent tube runs below fuel level. The tube opening must be placed above the fuel level.
2. Saddle tanks overflowing.	2. The equalizer line is small or plugged. Remove ice or restriction in line. Replace equalizer line with larger hose if required.
3. Overflowing shortly after filling.	3. The tank was brimmed with cold fuel which expanded when the fuel became warm. Do not fill tanks to the top with cold fuel.

H. Complaint: ENGINE FLOODED AT SHUT-DOWN

Cause	Correction
1. With under tanks.	1. Outlet from tank vent is above the level of the injectors and must be shortened. The vehicle may have been parked on a slope which placed vent above injector level.
2. With overhead tank.	2. Use float chamber to prevent fuel head pressure on injectors at shut-down.

I. Complaints: SUDDEN LOSS OF POWER OR POWER VARIES DURING OPERATION.

Cause	Correction
1. Fuel filter plugged or frozen.	1. Replace filter element with clean element. If frozen, thaw filter and drain the water from the can. Do not run without filter element.
2. Suction line restriction.	2. Check for rubber flaps or collapsed line. Install new suction line as required.
3. Suction air leak.	3. This will be accompanied by hard starting. Bleed fuel from the engine manifold into a glass bottle to detect air. Pressurize the suction side of the fuel system to find leak and fix as stated in step A-2.

J. Complaint: ENGINE DIES BUT WILL STARTT AND RUN AFTER RESTING.

Cause	Correction
1. Saddle tanks are not equalizing.	1. Check equalizer line for restriction and remove the obstruction or replace with larger line.

K. Complaint: THROTTLE HAS FLAT SPOT; THROTTLE DEAD. (USUALLY ASSOCIATED WITH LOSS OF POWER.)

Cause	Correction
1. Maximum throttle travel screw incorrectly - adjusted or has been unscrewed.	1. Readjust throttle lever setting on the calibration stand to specified limits or set on engine if the engine can be loaded to pull power. (See Fuel Pump Calibration)
2. Throttle linkage does not allow full opening.	2. Readjust linkage with proper clearance. Tighten pump throttle lever.
3. Suction restriction.	3. Replace fuel filter if plugged and check suction line for obstructions such as rubber flaps.
4. Suction air leak.	4. See A-2 and B-3.
5. Shutdown valve partially closed.	5. Set cable to obtain full opening of pump shut-down valve.

L. Complaint: ENGINE DIES WHEN DECELERATING; GOVERNOR DOES NOT CATCH ENGINE AT IDLE. ENGINE DIES AFTER COASTING.

Cause	Correction
1. Idle fuel calibration or throttle leakage has been set at less than specified 300 cc/min.	1. Set throttle leakage correctly. See D-4 and "Fuel Pump Calibration."

M. Complaint: ENGINE WILL NOT IDLE

Cause	Correction
1. Idle springs not assembled correctly or idle plunger stuck.	1. See D-4 and F-i. Assemble the spring pack correctly.
2. Idle jet in governor barrel plugged. housing to factory for repair.	2. Replace pump housing and return defective
3. Governor weights assembled incorrectly. washer. Check for correct assembly by removing the front cover of the pump and re-assembling the weight in correct position.	3. The weight feet must contact the thrust

N. Complaint: HIGH SPEED GOVERNOR NOT OPERATING.

Cause	Correction
1. Governor weights out of place on thrust washer.	1. Make correct assembly. See M-3.
2. Governor plunger stuck.	2. Determine the cause of sticking and replace damaged parts. The governor plunger may be freed by lapping with very fine compound

The governor barrel must be cleaned and flushed before operating on an engine or damage to the injectors may result.

3. Spring pack stuck.

3. Make inspection and determine cause of sticking
The plunger may be freed by lapping. Reset governor on the calibration stand.

O. Complaint: GOVERNOR CUTS IN AT LOW SPEED AT VARIABLE TIMES

Cause

1. Pump restriction.

Correction

1. The complaint is often heard when the fuel filter is plugging. A clean fuel filter will correct the trouble. If the suction line is collapsing, the same complaint may be heard; replace the old hose.

P. Complaint: CYLINDER MISSING OR ROUGH OPERATION

Cause

1. Leaking intake or exhaust valve.
2. Blown head gasket.
3. Leaking air connection from supercharger to intake air manifold.
4. Smashed or improperly repaired fuel - manifolds.
5. Restricted or frozen drain line. new line and fittings as required.
6. Stuck injector.
7. Plugged injector cup spray holes.
8. Plugged injector connection screens.
9. Improperly adjusted valves and injectors.
10. Plugged metering orifice in an injector.
11. Plugged drain orifice in an injector.

Correction

1. Remove cylinder head and repair.
2. Replace cylinder head gasket.
3. Repair or replace gaskets or parts as required to stop leaks.
4. Replace damaged manifolds with new parts.
5. Find source of restriction and eliminate using
6. Free the injector plunger and replace the injector if the injector body has been damaged.
7. Remove carbon with cleaning wires. The cup should be checked on the fixture for spray angle and shape.
8. Clean the screen with a carbon solvent, and air blast; a dirty screen will cause low power.
9. Re-set the overhead. Tight valves or loose injectors will cause the engine to be very rough.
10. The orifice should be carefully cleaned. See "Injector Testing" instructions. Check the injector by flow test to determine if cleaning has been complete. A plugged metering orifice will not cause the fuel pressure to change.
11. The manifold pressure will be approximately 10 psi high with a closed drain orifice and the

exhaust will be very dark at full load. Clean the orifice.

12. Broken or deformed injector cup gasket.

12. Install new cup gasket.

Note to Item "O": Never check for a missing cylinder at idle or with a cold engine. Always run at 800-1200 RPM when checking. Putting a load on the engine at low speed will help to locate a short cylinder. A heavy cylinder will show extreme heat at the exhaust port while running at full load.

Q. Complaint: EXCESSIVE IDLE SMOKE

Cause	Correction
1. Worn or improper injector cups. the correct size for each engine. Replace incorrect or worn cups with new cups.	1. For best performance the cup holes must be
2. Loose injector setting.	2. Reset the injectors to specified torque.
3. Leaking engine valves.	3. Remove cylinder heads and repair valves.
4. Leaking supercharger connection to intake air manifold.	4. Repair parts or replace as required to stop air leakage.

R. Complaint: POOR FUEL MILEAGE

Cause	Correction
1. Engine fuel rate set too high.	1. Recalibrate the fuel pump to give specified engine fuel rate.
2. Poor fuel.	2. Use clean fuel without water or gasoline added. The fuel should be within Cummins fuel specifications.
3. Loose or improperly set valves and injectors.	3. The overhead adjustment of an engine must be set correctly to obtain maximum performance and service.
4. Plugged injector cup spray holes or orifices.	4. See P-7, P-8, P-9, P-10 and P-11. The engine exhaust will be dark and the power will be low accompanied by low fuel mileage. Proper injector maintenance is required for good fuel mileage.
5. Leaking head gaskets and engine valves.	5. See Q-3, P-1, P-2. Repair the damaged parts in the engine; trouble in the engine is often attributed to the fuel system.
6. Excessive oil in the crankcase.	6. Drain the crankcase to the proper level; never run the crankcase level above the high limit as the rods may dip in the oil and cause a loss of power transmitted from the engine.
7. Restricted engine exhaust system or intake system.	7. Check the air cleaner for restriction and the engine muffler for carbon. The engine must breathe freely to operate efficiently.

5. Complaint: EXCESSIVE EXHAUST SMOKE

Cause	Correction
1. Engine fuel rate set above specified limit.	1. An overfueled engine will have a heavy exhaust and damage to the engine will result. Calibrate the fuel pump to specified limit for each model of engine.
2. Operation at high altitude or with hot intake air temperature.	2. Both high altitude and hot intake air decreases the air available to the engine. The air cleaner should be mounted to draw cool air into the engine and the engine fuel rate must be reduced for operating at high altitude.
3. Poor condition of engine rings, liners, valves, . gaskets, etc.	3. The engine must be in proper condition to develop maximum power at rated fuel. Repair damaged parts in the engine or the power will be low with resulting exhaust smoke.
4. Obstructed drain lines or drain manifold.	4. Poor deceleration may accompany this trouble. Check the drain connections, drain manifold and drain line for restrictions. See D-5, F-2 and P-5.
5. Plugged injector cups or injector orifices.	5. This complaint will be accompanied by low power, poor fuel mileage, etc. See R4, Q-2, Q.1.
6. Injectors set loose.	6. The plunger must seat firmly in the cup to prevent leakage and resulting smoke. Set injector at specified torque.

T. Complaint: EXCESSIVE MANIFOLD PRESSURE

Cause	Correction
1. Plugged drain orifice(s).	1. See P-11 and R-4. Clean and check the orifices. See "Injector Test Instructions."
2. Plugged drain line.	2. This will be accompanied by dark exhaust and poor deceleration. See D-5. The drain line must be No. 8 Stratoflex or equivalent hose. Remove restriction; replace line and fittings as required.
3. Non-vented fuel tank.	3. If the fuel tank vent is below the fuel level or if the vent is damaged, pressure will build up in the tank and on the drain side of the injector. Repair or install the proper tank venting system.
4. Restricted inlet manifold leaders. system.	4. Check the inlet manifold for restrictions or damage. Replace with new parts as required. The engine power will be low.

5. Clogged inlet connector screens.
6. Governor set above specified speed. crease in speed. Calibrate the governor on the test stand to the specified limits.
7. Heavy fuel.

5. The screens should he cleaned regularly but may become dirty with dirty fuel. Clean with carbon solvent and air blast. The engine power will be low.
6. The manifold pressure increases with an in-
7. A very viscous fuel will cause the fuel pressure to increase with no change in engine performance . Do not change the pump setting; use approved fuel.

U. Complaint: LOW MANIFOLD PRESSURE

Cause	Correction
1. Throttle not fully open.	1. Check the throttle linkage and set to obtain full throttle travel at the pump.
2. Excessive restriction in the pump suction line or fuel filter.	2. Check lines for rubber flaps or loose lining and replace if required. Change the filter element to restore fuel pressure and power. See 0.1, K-3, I-1.
3. Air leaks in suction line.	3. Pressurize the suction line to locate leak point. See A-2, A-3, B-3, I1-3, K4.
4. Light fuel.	4. A low viscosity fuel or fuel with an additive such as gasoline will cause low fuel pressure. Do not change the fuel pump calibration; use approved fuel.
5. Shut-down valve partially closed.	5. Check the cable and adjust to obtain full opening of the shut-down valve.
6. Restriction in public from pump to inlet manifold.	6. Replace the tube from the pump-to-the-manifold fold if damaged.
7. High speed governor set too low. correct specified setting for the engine.	7. Calibrate the governor on the test stand to the
8. Gear pump worn or scored.	8. If the damage to the gear pump is not severe enough to cause hard starting (See B-1) recalibrate the pump on the test stand to correct setting. If hard starting is also present, replace the gear pump with a new assembly.

V. Complaint: LOW POWER

Cause	Correction
1. Low fuel pressure.	1. Check with an accurate gauge at the shut-down valve tap. See U-1 through U-8.

2. Suction line air leaks.
3. Throttle not fully open.
4. Shut-down valve partially closed.
5. Leaking pressure regulator cap seal ring.
6. Suction restriction.
7. Pressure regulator stuck in open position.
8. Plugged filter screen at top of pump.
9. Dirty inlet connection screens.
10. Injector(s) stuck.
11. Mutilated or restricted fuel piping.
12. Improperly set valves and injectors.
13. Injectors loose and not seated in the cylinder head sleeve.
14. Dirt in the injector orifices or injector cup spray holes.
2. Bleed a small amount of fuel from the inlet manifold into a glass bottle and observe for air. Pressurize the suction side of the system to locate the leak. See A-3, A4, B-3, 1-3, K4, U-3.
3. Check and adjust throttle linkage to insure full throttle travel. See D-1, D-2.
4. See U-5. Adjust cable for full travel.
5. See A4. Replace the seal and use a lubricant on the seal during assembly.
6. Check the inlet connection of the gear pump, with a suction gauge ST-434. See 0-1, K-3, I-1 and U-2. Run the engine at maximum speed and no load while checking. The gauge reading must not exceed 8 1/2 inches, mercury.
7. The plunger may be freed with fine lapping powder if not seriously damaged. See A-5.
8. Clean the screen with carbon solvent and air blast. Replace only if the screen is damaged.
9. Clean regularly. See T-5.
10. Free the injector plunger and replace the injector assembly if damaged. Water in the fuel is the most serious cause of injector sticking. Always check for water in the engine cylinder in the fuel filter and in the fuel tanks if an injector sticks. See P-6.
11. Check the tubing and hose on both the step-ply and drain side of the fuel system for restrictions. Replace defective parts.
12. The engine overhead setting is the key to best performance. Reset the valves and injectors at regular intervals.
13. Always clean the seat in the cylinder head before installing an injector. If not seated, the combustion gas will leak past the injector cup. This may be detected at idle by bubbles blowing up the copper sleeve around the injector body.
14. The injector orifices should be checked by the specified flow test. "Refer to Injector Testing Instructions." See P-7, P-8, P-10, P-11.

- 15. Poor fuel.
- 16. High speed governor set too low.
- 17. Engine fault.
- 18. Vehicle fault.
- 19. Faulty chassis dynamometer or wheel power dynamometers indications.
- 15. Water or additives such as gasoline may be in the fuel. See T-7, U-4.
- 16. On some operations an incorrect governor setting may be confused for low power. Set the governor on the calibration stand to the specified limits.
- 17. Such things as burned valves, burned piston, scored liners, breathing restriction or an engine out-of-time will cause low power. The fuel rate must not be raised to compensate for a damaged part in the engine; the engine repair will restore the lost power.
- 18. Worn transmissions, dragging clutch, brakes, unmatched tires and improper gear ratios will result in low power complaints. The fuel rate must not be raised in an attempt to compensate for vehicle faults or the engine will be damaged.
- 19. Because of the variables inherent in measuring power from the engine through a series of transmissions, gears, and wheels is such that the efficiency of each separate component affects the final indications, the wheel power reading must not be regarded as an absolute value. At best it can be used for comparative estimates, only.

Note to Item 'V':

In general, the complaint of low power will be the most troublesome to correct because of the many variables in operations and installations as well as the difficulty of correctly measuring power in the field. With the PT fuel system, the trouble-shooter can often eliminate the pump as the source of trouble simply by checking to see that the manifold pressure is within specified limits. The fuel rate of the pump must not be increased to compensate for a fault in other parts of the vehicle; damage to the engine will result.

The service man should check maximum manifold pressure and pump suction pressure first in order to quickly locate the trouble either in the pump or the engine. Use ST-434 to check gear pump suction and ST-435 to check manifold pressure.

The best way to check pressures on the engine is while operating at full load and full speed using an engine dynamometer or a chassis dynamometer. In a vehicle, maximum pressure checks can be made by pulling up a hill in a gear which will slowly accelerate the vehicle to the governed speed of the engine. A less accurate method is to operate the engine at 400 RPM below governed speed: then accelerate the engine with full throttle and check the maximum pressures indicated on the gauge.

CHART NO. 1

HARD STARTING OR FAILURE TO START

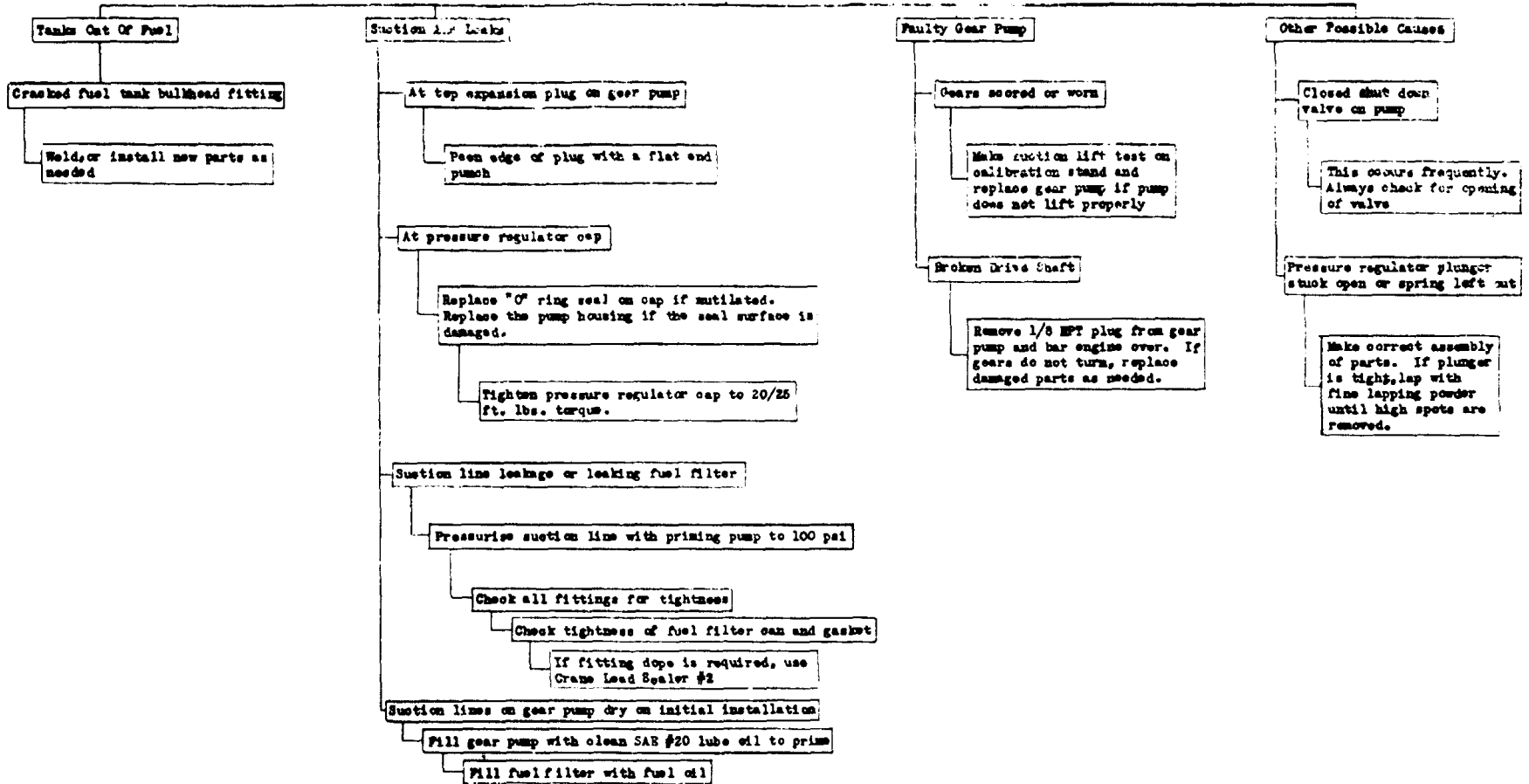

CUMMINS PT FUEL SYSTEM

CHART NO. 2

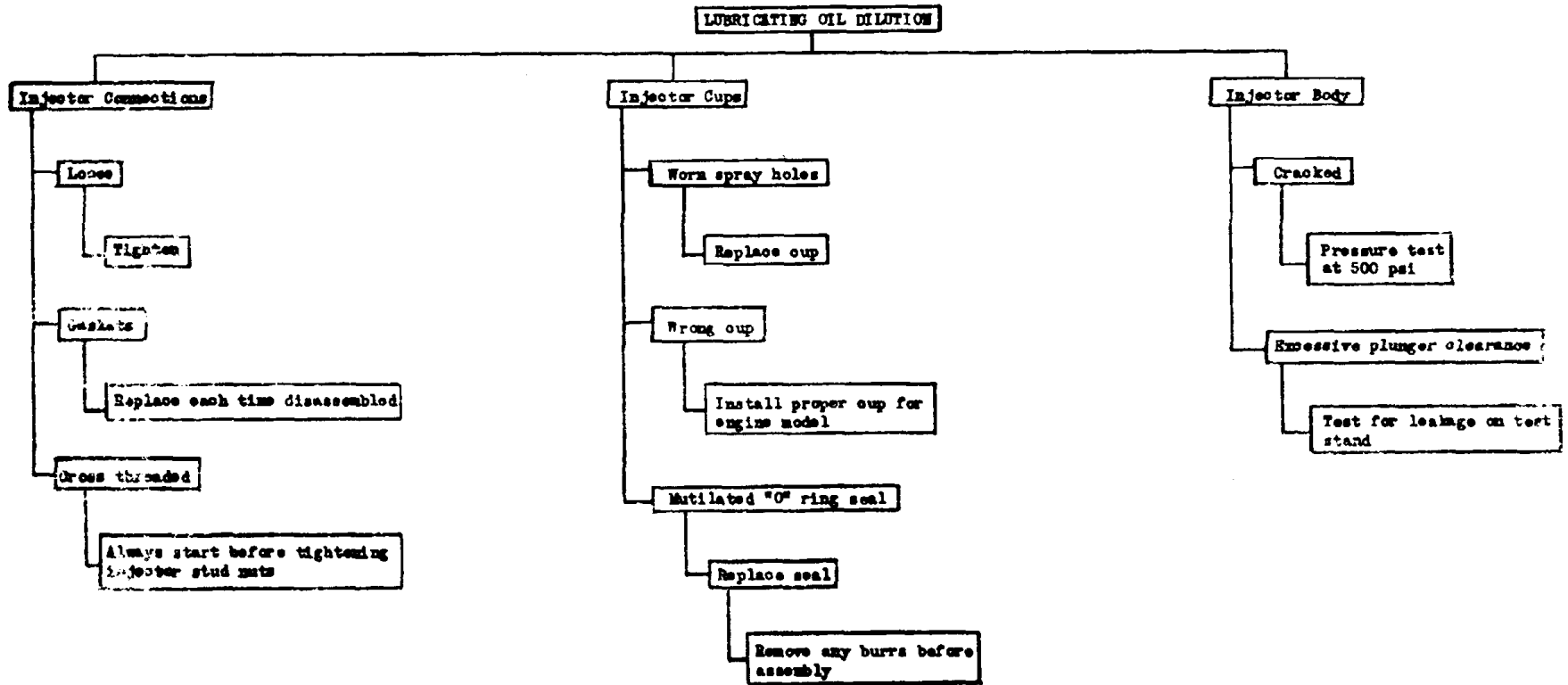

CUMMINS PT FUEL SYSTEM

CHART NO. 3

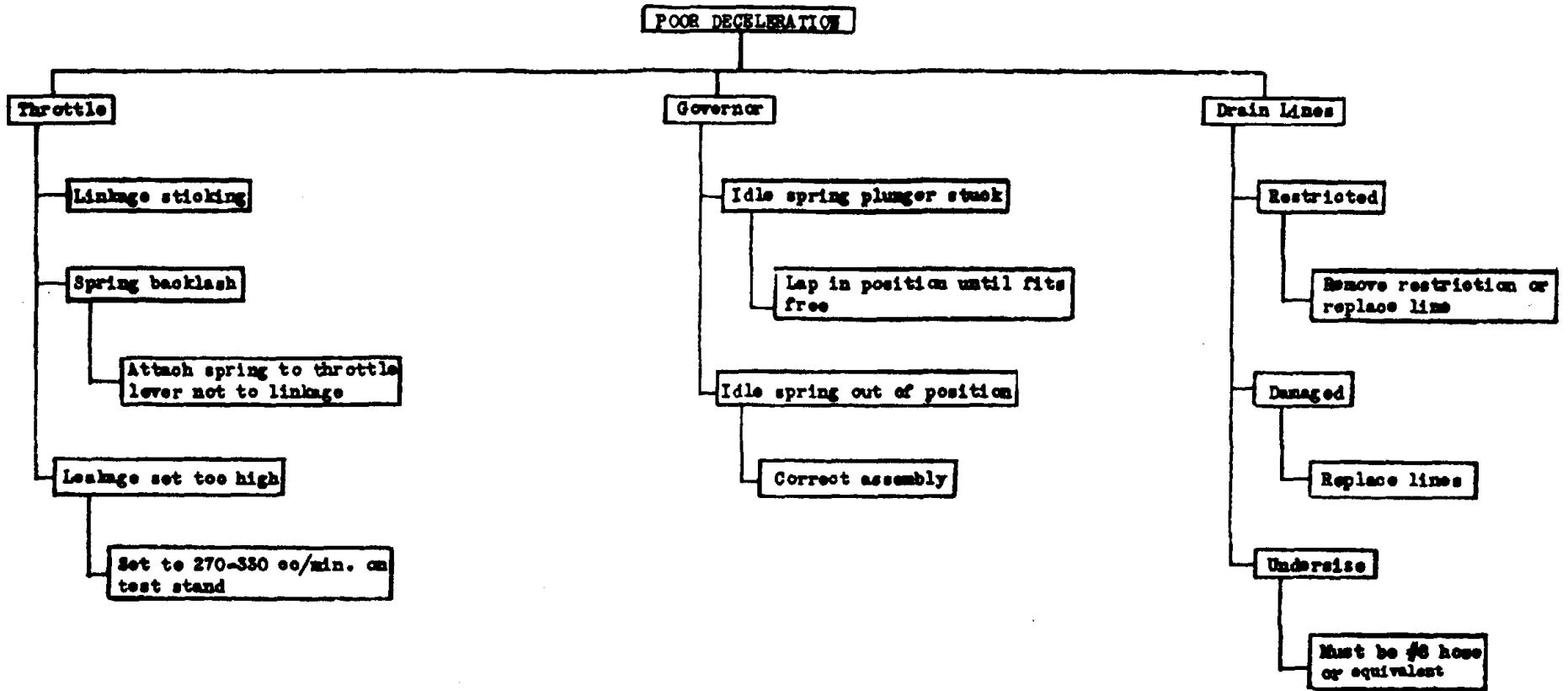

CUMMINS PT FUEL SYSTEM

CHART NO. 4

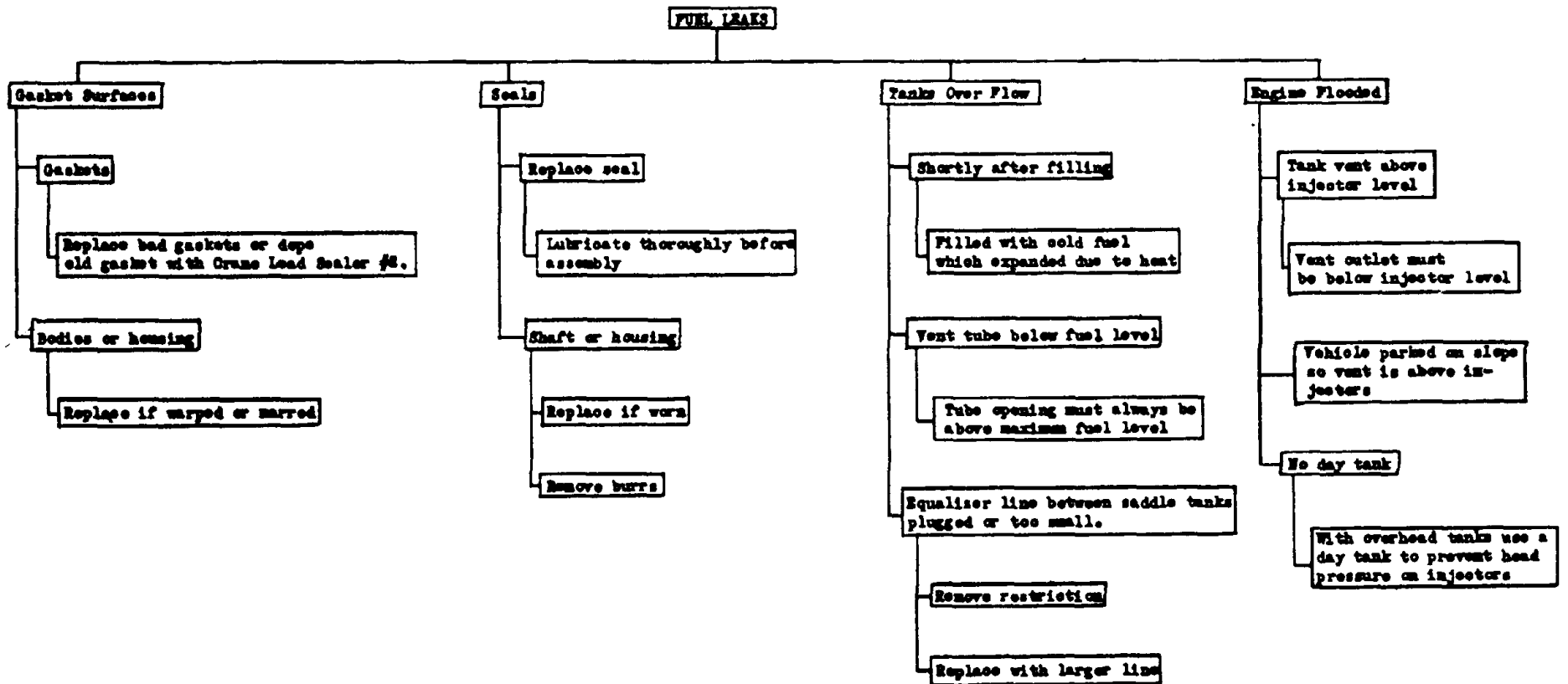

CUMMINS PT FUEL SYSTEM

CHART NO. 5

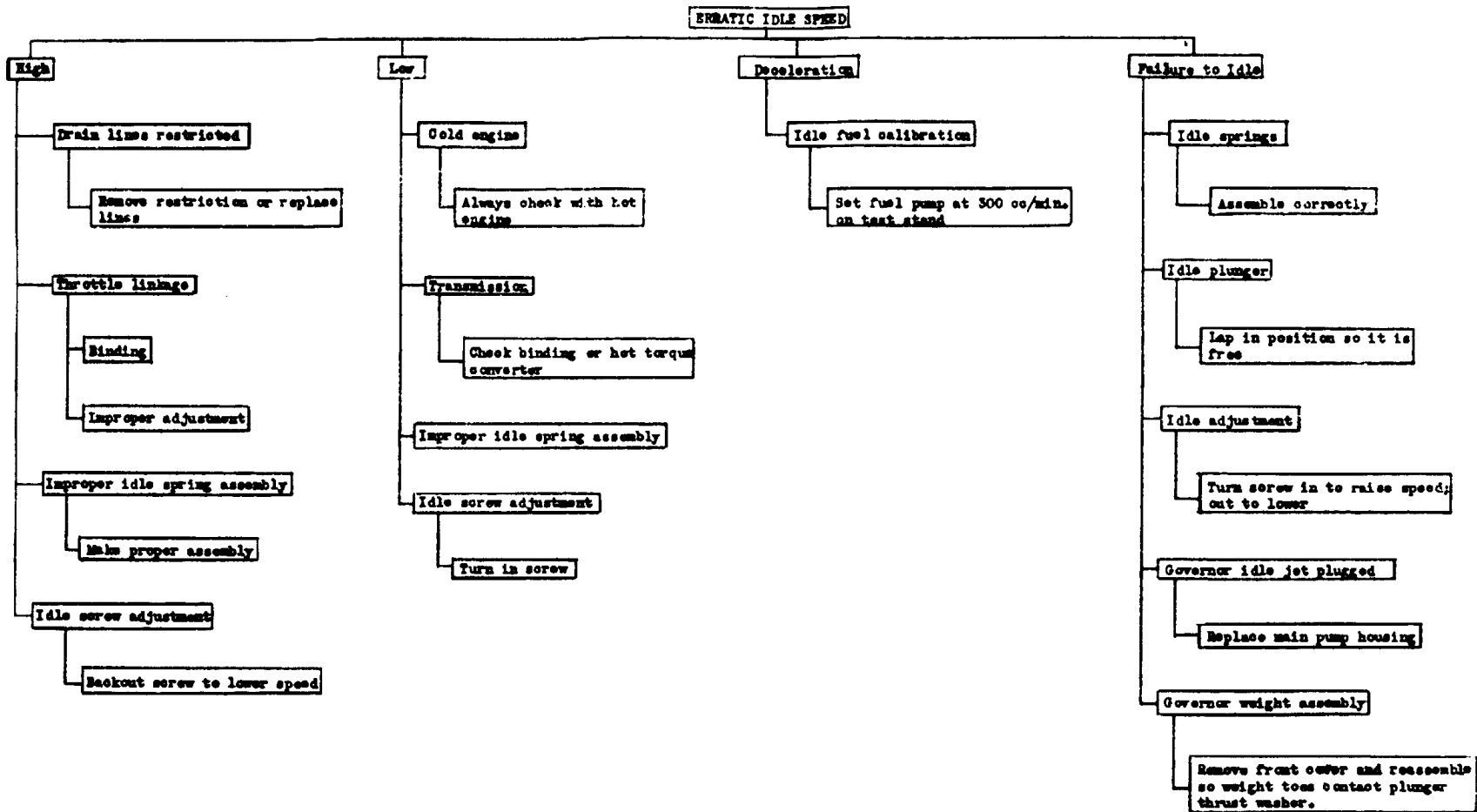

NOTE: See Chart No. 8 "Erratic Governor Action".

CUMMINS PT FUEL SYSTEM

CHART NO. 6

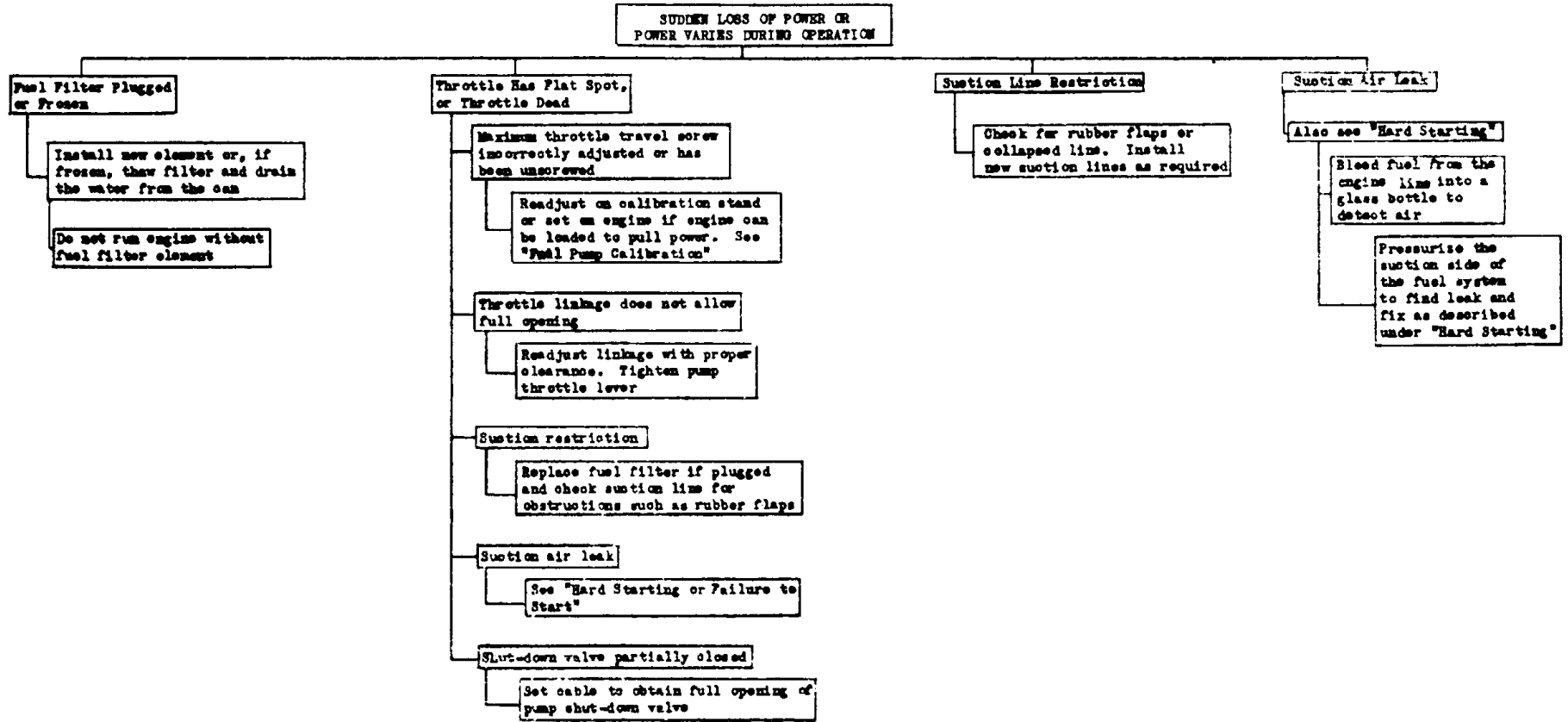

CUMMINS PT FUEL SYSTEM

CHART NO. 7

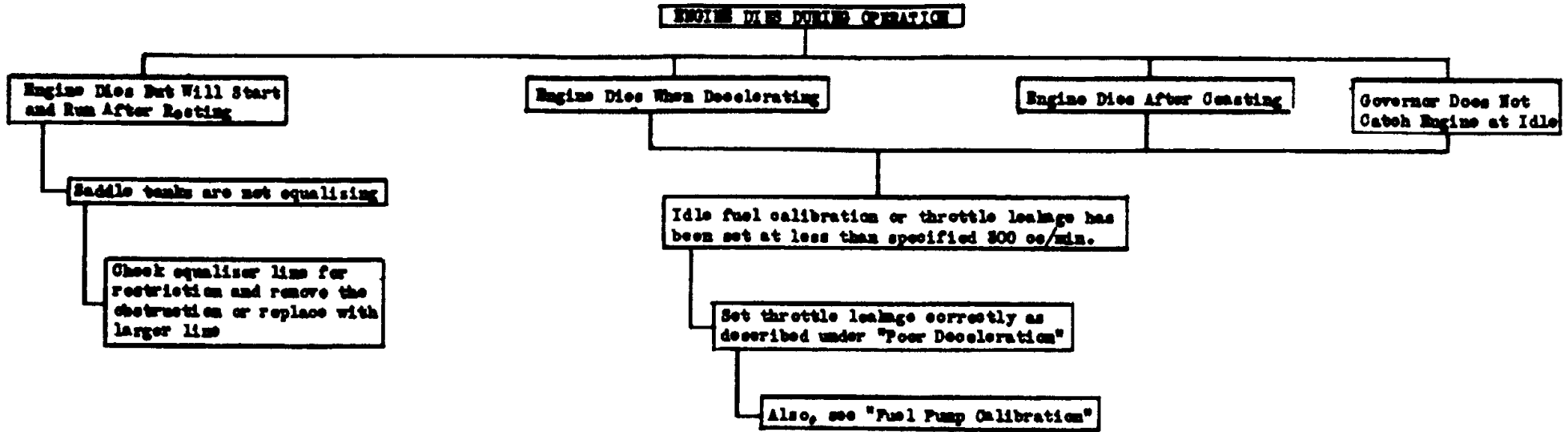

CUMMINS PT FUEL SYSTEM

CHART NO. 8

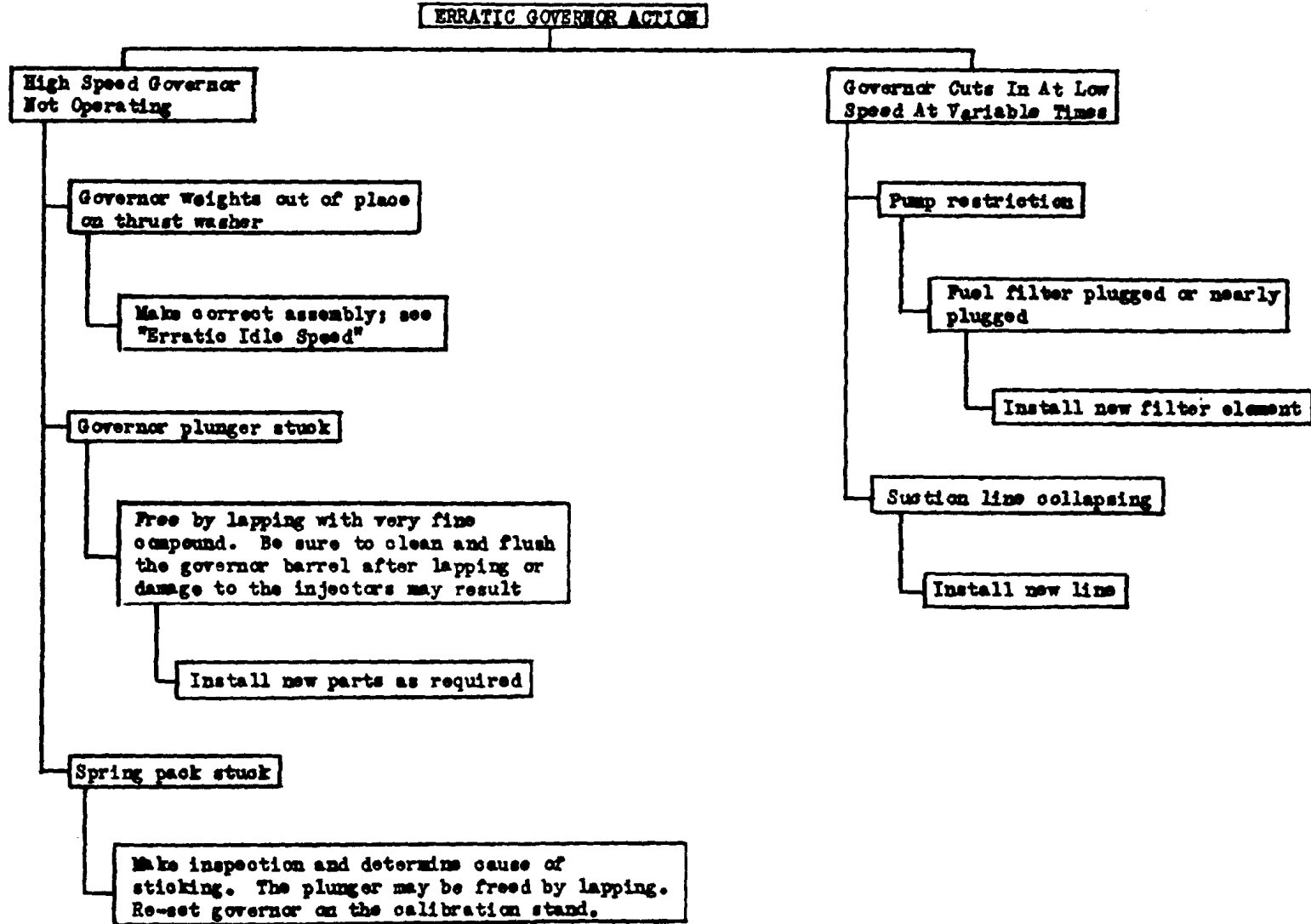
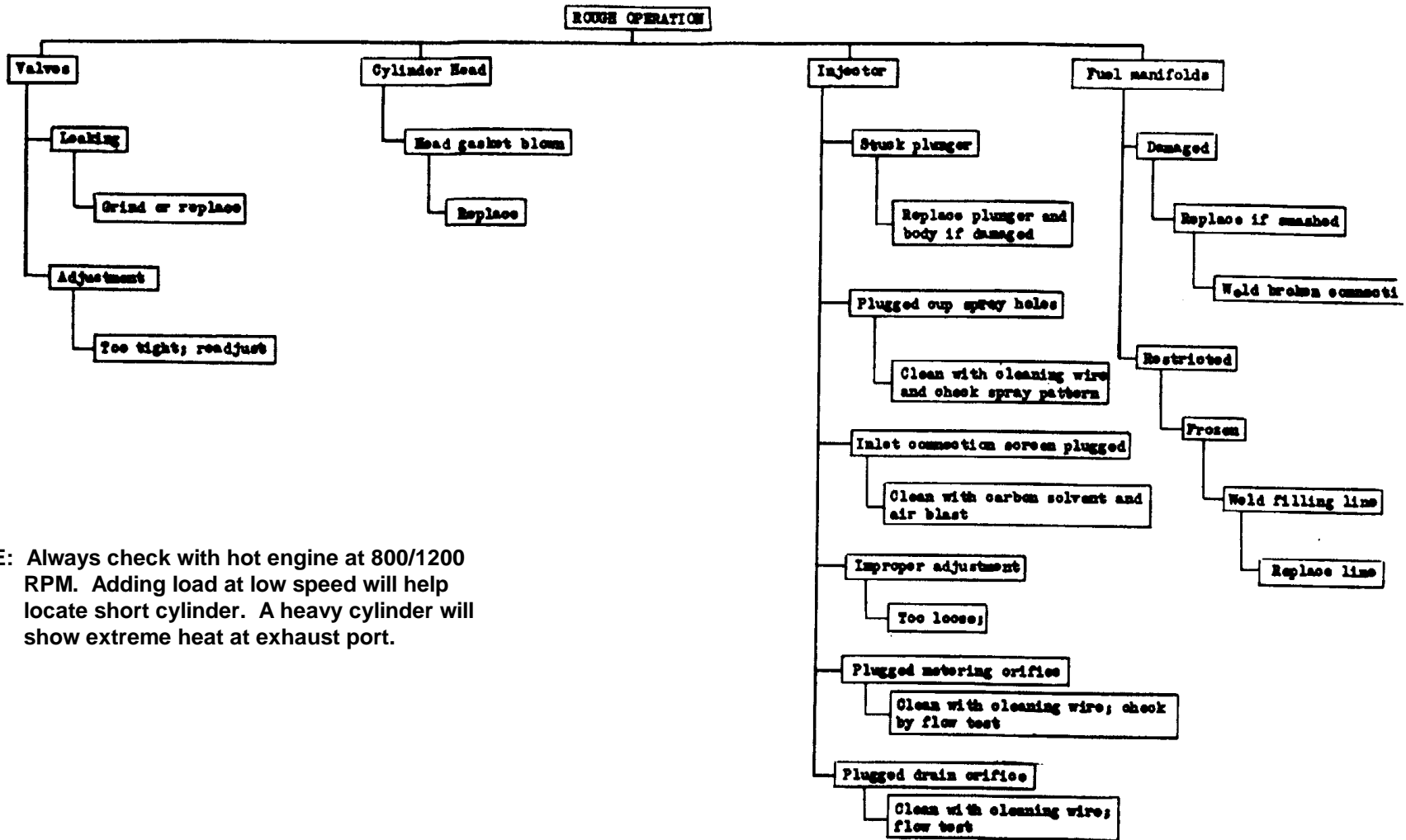
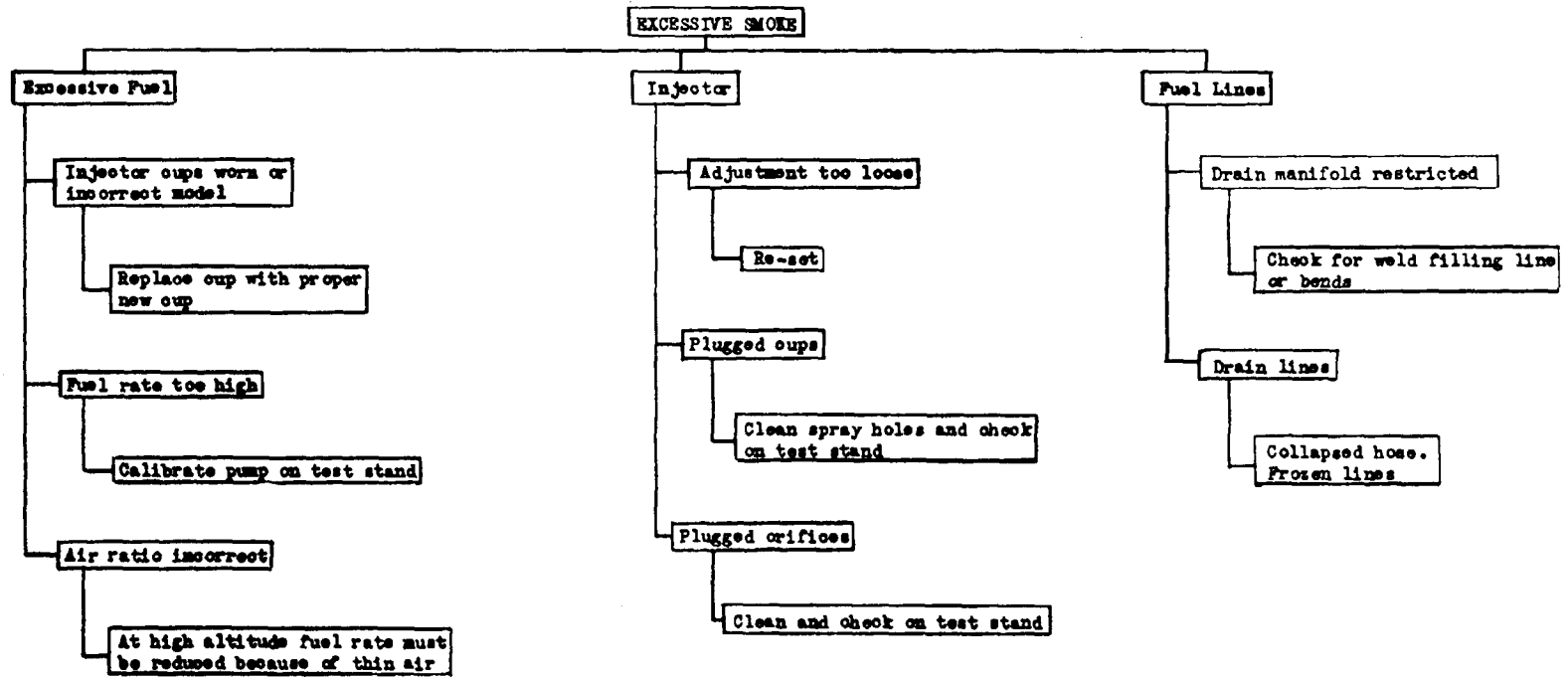

CHART NO. 9



NOTE: Always check with hot engine at 800/1200 RPM. Adding load at low speed will help locate short cylinder. A heavy cylinder will show extreme heat at exhaust port.

CHART NO. 10



NOTE: Worn valves, rings and liners or other engine parts can also cause excessive smoke. The Fuel System is often blamed when other engine parts are the fault

CUMMINS PT FUEL SYSTEM

CHART NO. 11

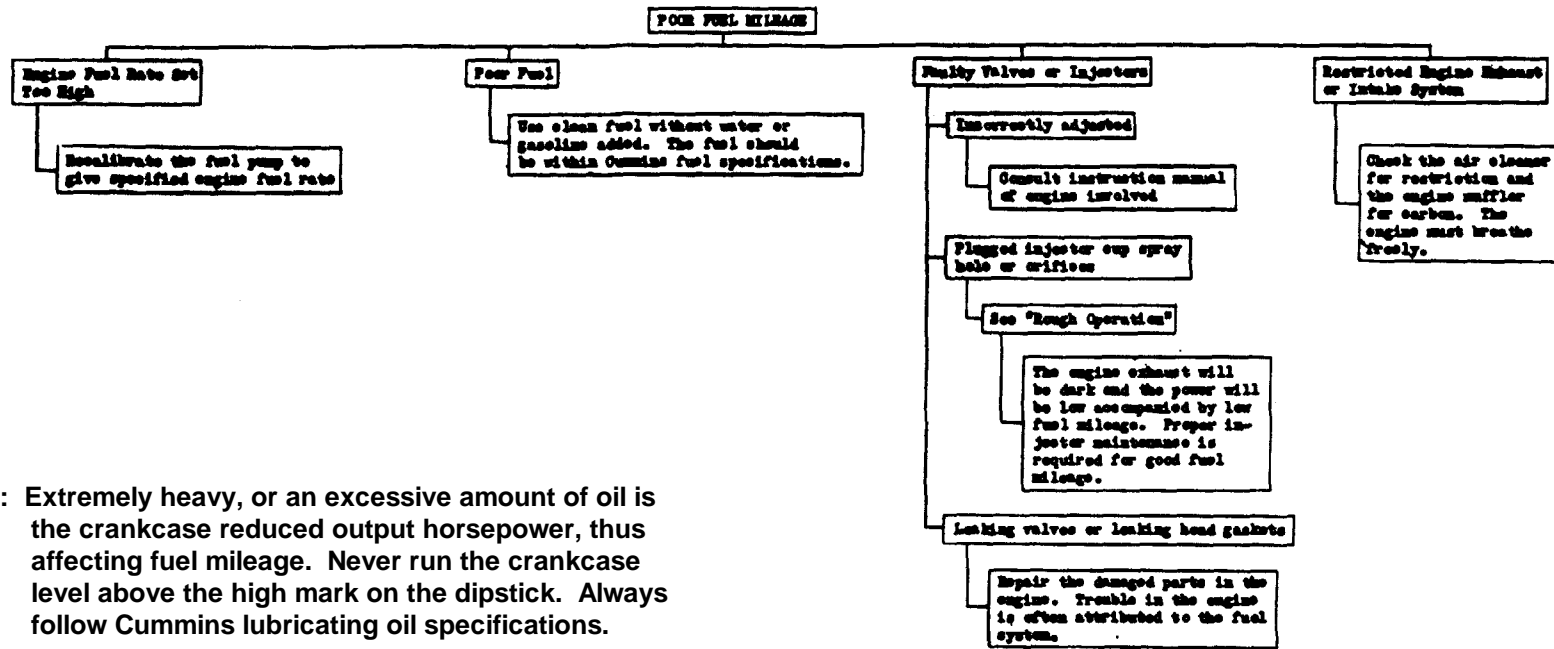

NOTE #1: Extremely heavy, or an excessive amount of oil in the crankcase reduced output horsepower, thus affecting fuel mileage. Never run the crankcase level above the high mark on the dipstick. Always follow Cummins lubricating oil specifications.

NOTE #2: A thorough study of all phase of engine operation should be made when a "poor fuel mileage" complaint is registered. The gross load versus engine rated horsepower is one important factor. The type of holiday, steepness of inclines, gear splits and road speed are factors that have a direct effect on fuel mileage.

CUMMINS PT FUEL SYSTEM

CHART NO. 12

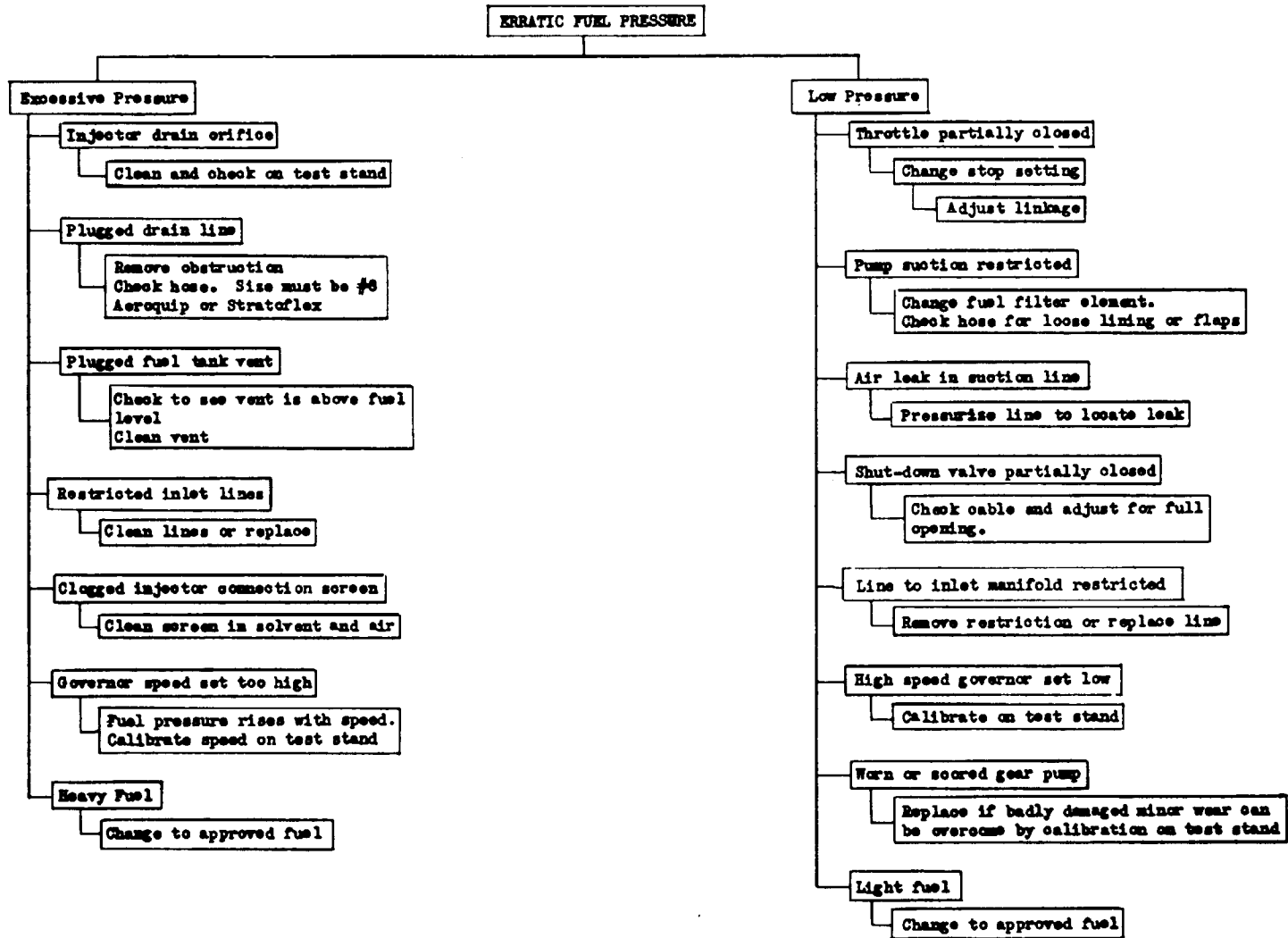

CUMMINS PT FUEL SYSTEM

CHART NO. 13

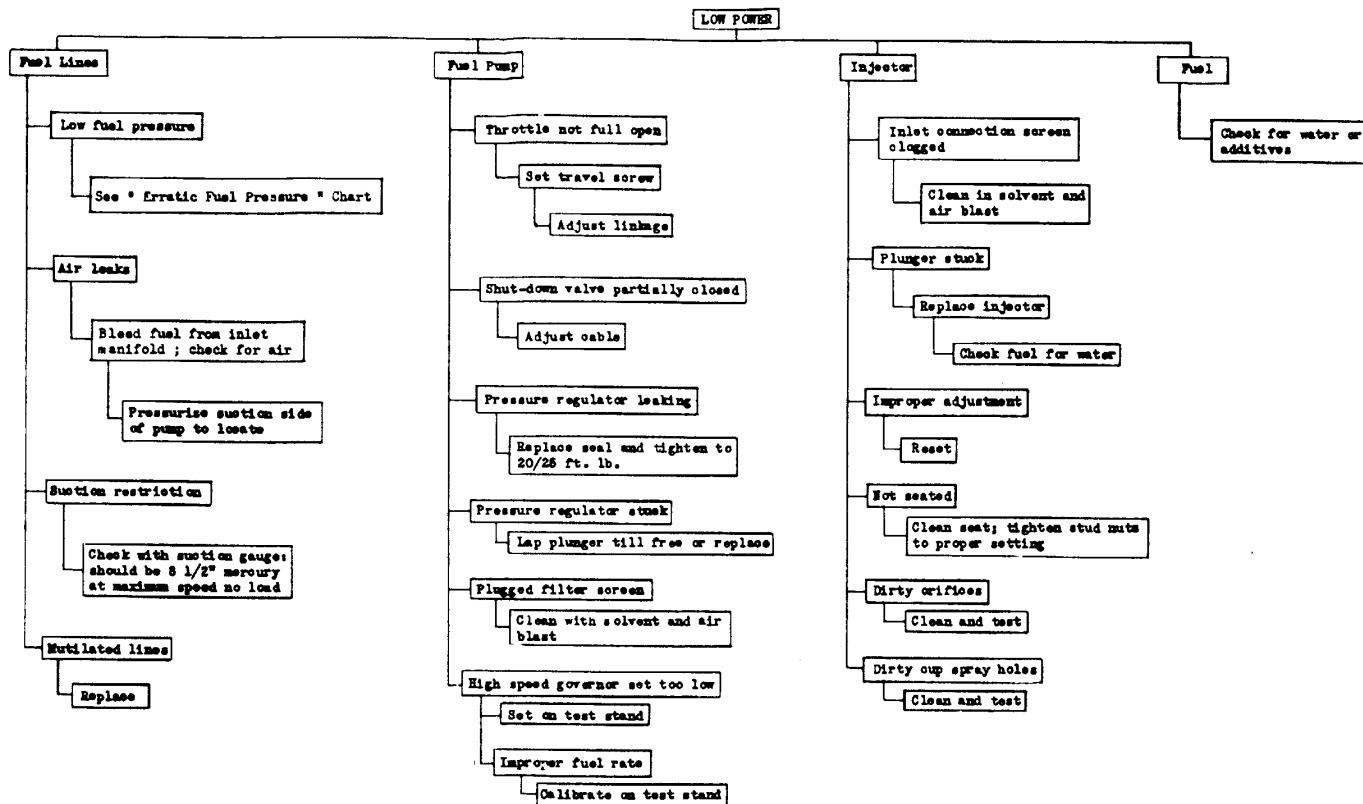

NOTE: Other parts of engine or vehicle are more often the cause of low power, among these are, valves burned pistons scored liners, air restriction engine out of time, worn transmissions, dragging clutch, unpatched tires and improper gear ratios. Comparative readings from a dynameter will help locate these faults. However because of inherent variable the dynameter should not be used as an absolute trouble indication.

CUMMINS PT FUEL SYSTEM

*U.S. GOVERNMENT PRINTING OFFICE: 1981 0 356-876/2875

RECOMMENDED CHANGES TO EQUIPMENT TECHNICAL PUBLICATIONS



THEN...JOT DOWN THE DOPE ABOUT IT ON THIS FORM. CAREFULLY TEAR IT OUT, FOLD IT AND DROP IT IN THE MAIL.

SOMETHING WRONG WITH PUBLICATION

FROM: (PRINT YOUR UNIT'S COMPLETE ADDRESS)

DATE SENT

PUBLICATION NUMBER

PUBLICATION DATE

PUBLICATION TITLE

BE EXACT PIN-POINT WHERE IT IS

PAGE NO.	PARA-GRAPH	FIGURE NO.	TABLE NO.

IN THIS SPACE, TELL WHAT IS WRONG AND WHAT SHOULD BE DONE ABOUT IT.

PRINTED NAME, GRADE OR TITLE AND TELEPHONE NUMBER

SIGN HERE

PIN: 021269-000